

DETAILLIJST

OPLIGGER, GESLOTEN OPBOUW: 6 ton, 2 wielen, DL, YAA-602 (DAF)
NSN 2330-17-022-0065

OPLIGGER, VRACHT: 6 ton, 2 wielen, DL, YAA-612 (DAF)
NSN 2330-17-022-0066

TECHNISCHE DIENST



Aangebrachte „Opgaven van Wijziging“

nummer	nummer	nummer	nummer	nummer	nummer
1 ^e 290991	3 ^e 140272	5 ^e 240572	11 ^e 06474		
2 ^e 200172	4 ^e 220579	6 ^e 150073	8 ^e		

Vastgesteld door de Inspecteur van de technische dienst bij brief nr. ITD/Doc/63.899/11-E
dd. 7 november 1969.

T O E L I C H T I N G

1. De op de afbeeldingen voorkomende artikelen zijn aangeduid met een cijfer, aanvangende met 1. Indien een artikel meer dan één keer op een pagina is afgebeeld, dan dragen de afbeeldingen van dit artikel (figuren) dezelfde aanduiding.
2. In de kolom 3 "Artikelomschrijving" is de officiële naam van het artikel aangegeven in kapitale letters.
- 3.^a De artikelen waarbij geen stocknummer is vermeld, zijn geen bevoorradingsartikelen.
- 3.^b De artikelen, waarbij in de kolommen 2^e, 3^e en 4^e echelon geen + teken is opgenomen, mogen slechts worden aangewend tbv het 5^e echelonsonderhoud.
4. Een aantal genoemd in de kolom 4 van Deel 2 "Aantal gemonteerd" heeft betrekking op het aantal gemonteerd in de betrokken subgroep.
5. Indien niet anders is aangegeven in de kolom "Opmerkingen" is de rekeneenheid van het artikel stuks.
6. Betekenis van de in de kolommen 2^e, 3^e en 4^e echelon voorkomende tekens:
 - + = het artikel mag worden verstrekt c.q. aangewend ten behoeve van het desbetreffende onderhoud
 - %% = het artikel mag uitsluitend worden aangewend bij het onderdeelsonderhoud indien daarvoor toestemming is gegeven door de onderhoudsofficier van de steunende hersteleenheid.
7. Betekenis van de afkortingen in de kolom "Opmerkingen":
 - DKMG/SBG = aanvragen bij de Dienst van de Kwartiermeester Generaal, Sectie Boekwerken en Gedrukten
 - DKMG/MVA3 = aanvragen bij de Sectie Materieelverzorging Bureau Bevoorrading Uitrustingsstukken van de Materieelvoorzieningsafdeling 3
 - fig = figuuraanduiding van een op een afbeelding voorkomend artikel.
 - i = het artikel moet bij vervanging worden ingeleverd
 - int = het artikel behoort tot de materieelsector van de intendance
 - vbdd = het artikel behoort tot de materieelsector van de verbindingdienst
 - r = het artikel moet wanneer het onbruikbaar is, ter herstelling worden aangeboden. Indien herstelling bij de steunende hersteleenheid niet mogelijk is, dan moet een aanvraag ter vervanging worden ingediend en het onbruikbare artikel worden ingeleverd.
 - za = zelfstandig aanmaken c.q. aanschaffen.
8. Op blz 57 t/m 94 zijn 2 indexen opgenomen t.w.:
 - een NSN-index met verwijzing naar fabrieksnummer, bladzijdenummer en artikelvolgnummer
 - een Fabrieksnummer-index met verwijzing naar bladzijdenummer en artikelvolgnummer
9. Lijst van fabrikantencodenummers:
 - H0001 = Van Doorne's Automobielfabriek N.V., Eindhoven
 - H0002 = Philips Gloeilampenfabrieken, N.V., Eindhoven
 - H0007 = Koning Azn, N.V. "KONI", J. de, Oud Beijerland
 - U0042 = Sankey, Gr Brittannië
 - H0050 = White Products, Rotterdam
 - K0092 = Lockheed hydr Brake Co Ltd
 - H0099 = Kwartiermeester-Generaal, 's-Gravenhage

I N H O U D

Deel I

Toebehorende delen	blz 2
Bijgevoegde reservedelen	blz 2
Bijgevoegde documentatie	blz 3

Deel II

Tekst met Afbeeldingen

<u>Groep</u>	<u>Benaming</u>	<u>Afbeelding nr</u>	
06	ELEKTRISCHE INSTALLATIE	0601	blz 9 t/m 16
0608.00	VERDEELKAST, SMELTPATRONEN en CONNECTOR, DOOS, binnenverlichting (alleen voor NSN 2330-17-022-0065)		blz 9
0609.00	STADS-, GRENS-, STOP-/ACHTERLAMPEN en HULPLAMPEN	0601	blz 9 t/m 12
0612.00	ACCU en GELIJKRICHTER (alleen voor NSN 2330-17-022-0065)		blz 12 en 13
0613.00	BEDRADING		blz 13 t/m 16
0613.50	VOLGWAGENKOPPELING		blz 16
11	AS		blz 17
1100.00	AS, cpl		blz 17
1101.00	ASLICHAAM		blz 17
12	REMINSTALLATIE	1201 t/m 1207	blz 17 t/m 42
1201.00	HANDREMINSTALLATIE	1201	blz 17 t/m 19
1202.00	WIELREMINSTALLATIE	1202, 1301	blz 20 en 21
1204.10	HOOFDREMCIJLINDER en REMVLOEISTOFTANK	1203	blz 21 t/m 23
1204.20	WIELREMCIJLINDERS	1202	blz 23 t/m 25
1204-50	HYDRAULISCHE LEIDINGEN en AANSLUITINGEN	1203	blz 25 en 26
1208.00	REMBEKRACHTIGER	1203	blz 26 en 27
1208.10	LUCHTFILTER, LUCHTLEIDINGEN en AANSLUITINGEN	1203, 1204	blz 28 t/m 31
1208.20	LUCHTKETELS		blz 31 en 32
1208.50	AFSLUITER, VEILIGHEID	1205	blz 32 en 33
1208.70	REACTIE-VEILIGHEIDSVENTIEL en REMKRACHTREGELAAR	1206, 1207	blz 33 t/m 41
1211.00	SLANGKOPPELING		blz 41 en 42
13	NAVEN, REMTROMMELS en WIELEN	1301	blz 42 en 43
1311.00	NAVEN, REMTROMMELS en WIELEN	1301	blz 42 en 43
1313.00	BANDEN		blz 43
15	CHASSIS	1501	blz 44 en 45
1501.00	CHASSISRAAM		blz 44
1504.00	RESERVEWIELDRAGER		blz 44
1506.00	KOPPELPEN		blz 45
1507.00	PARKEERSTEUN	1501	blz 45

I N H O U D (vervolg)

<u>Groep</u>	<u>Benaming</u>	<u>Afbeelding nr</u>
16	VERING en SCHOKBREKERS	blz 45 t/m 47
1601.10	VERING	blz 45 t/m 47
1604.00	SCHOKDEMPER	blz 47
18	LAADBAK	blz 47 t/m 54
1808.00	OPBERGMIDDELEN, v/VOERTUIGUITRUSTING	blz 47 t/m 49
1810.00	LAADBAK (alleen voor NSN 2330-17-022-0065)	blz 49 t/m 51
1810.00	LAADBAK (alleen voor NSN 2330-17-022-0066)	blz 51 t/m 54
22	OPBOUW en ROMPTOEBEHOREN	blz 55
2201.00	ZEILEN (alleen voor NSN 2330-17-022-0066)	blz 55
2202.00	REFLECTOREN	blz 55
2210.00	INSTRUCTIE- en IDENTIFICATIEPLATEN	blz 55
Verwijzingslijst		
NSN		blz 57 t/m 77
Fabrieksnr		blz 79 t/m 94

T O E L I C H T I N G (vervolg)

9. Lijst van fabrikantencodenummers:(vervolg)

H0206 = Hazemeyer & Co., N.V. FABRIEK VAN ELECTRISCHE APPARATEN V/H F., Hengelo
H0711 = Insp Techn Dienst, 's-Gravenhage
H1266 = Nederlands Normalisatie Instituut, Stichting (NNI), 's-Gravenhage
H1370 = Wolf, Firma A, Rotterdam
H1650 = MMS-X-Bladen Koninklijke Marine, 's-Gravenhage
U1980 = Ford Motor Co Ltd, Dagenham Essex, England
Ford Motor Co Ltd Parts Division, Aveley Depot South Ockendon, Essex, England
D2342 = Goetze Werke Durscheid
H2428 = "NELIMEX" INDUSTRIE- EN HANDELSONDERNEMING, Heemstede (fabriek te Overveen)
D2598 = Si Cherung - Bau GMBH Lunen Westfalen, Germany
H3067 = Groenewegen N.V. fabr v/aanhangwagens en opleggers, Parallelweg 13, ETTEN (N Br)
03477 = Anderson Bros MFG Co, Rockford, Ill
04636 = Austin-Western Works Baldwin Lima-Hamilton corp Construction Equipment Division Aurora Ill
00000 = Ordnance Section U.S. Army
23000 = Aircraft Technical Service Inc, 16021 Arminta St van Nuys, Calif
24617 = General Motors Corp, Detroit, Mich
63477 = Wagner Electr Corp, St, Louis, MO
65909 = Willys Motors Inc, Toledo, Ohio
78500 = Timken-Detroit Axle Div of Rockwell-Standard Corp, Detroit, Mich
96906 = Military Standard Promulgated Standardization Div Directorate of logistic Services DSA

10. Op blz 57 t/m 94 zijn 2 indexen opgenomen t.w.:

- een NSN-index met verwijzing naar fabrieksnummer, bladzijdenummer en artikelvolgnummer.
- een fabrieksnr-index met verwijzing naar bladzijdenummer en artikelvolgnummer.

In deze detaillijst zijn de gegevens verwerkt, welke bekend waren op 1 oktober 1969.

Hiermede vervalt de TD 7-8 SNL GN-329 van oktober 1958 en de hierop verschenen wijzigingen.

DEEL I

Overzicht van de

- toebehorende delen
- bijgevoegde reservedelen
- bijgevoegde verbruiksartikelen
- bijgevoegde documentatie

Volgnr	Artikelnummer			Artikelomschrijving	Aantal	Opmerkingen
	NATO Stocknummer	Fbr C nr	Fabrieksartikelnummer			
	1	2	2a			
				OPLEGGER, GESLOTEN OPBOUW: 6 ton, 2 wielen, DL, YAA-602 (DAF) OPLEGGER, VRACHT: 5 ton, 2 wielen, DL, YAA-612 (DAF)		
				<u>Toebehorende delen:</u>		
1	5340-17-036-9366			HANGSLOT, voorzien van verdek	2	int i
2	3990-17-003-4680	H0001	133305	LAADBRUG, VOERTUIG, St, v/laden (alleen voor NSN 2330-17-022-0066)	2	i
3	5120-17-026-5776	H0001	135843	SLEUTEL, SOK, enkele sok, zes, SW 32 mm (te gebruiken m/wringstaaf NSN 5120-17-026-5773)	1	i
4	5120-17-031-1012			SLEUTEL, STEEK-, dubbele bek, bekh 15°, SW 16 mm en 17 mm	1	i
5	5120-17-026-5773	H0001	135884	WRINGSTAAF, SLEUTEL, diam 1 1/16 in, L 500 mm	1	i
				<u>Bijgevoegde reservedelen:</u>		
6				WIEL, LUCHTBAND, cpl	1	i
				<u>artikelomschrijving samengesteld artikel:</u>		
7	2610-17-002-9823			1 - BAND, LUCHT, BINNEN, 9.00-20, m/ventiel		i
8	2610-17-002-9817			1 - BAND, LUCHT, BUITEN, 12 koordlagen, terreinprofiel, 9.00-20		i
9	2640-17-022-5329			1 - VELGLINT, ru, 9.00-20 (type 20N)		
10	2640-17-003-7617			1 - VENTIEL, LUCHTBAND, bu, cpl, opdraaibaar, 2 maal gebogen		
11	2530-17-017-6848			1 - WIEL, LUCHTBAND, m/SLOTRING en VELGRING, 6.50-20, bolling 142		i
				<u>Bijgevoegde verbruiksartikelen:</u>		
				GEEN		
				<u>Bijgevoegde documentatie:</u>		
12				BEDIENINGS- en ONDERHOUDSVOORSCHRIFT, TH9-329	1	DKMG/SBG
13				1 DL/2330-17-022-0065	1	DKMG/SBG
14				KENTEKENBEWIJS	1	DKMG/MVA3 i

Detaillijst NSN 2330-17-022-0065

Volgnr	Artikelnummer			Artikelomschrijving	Aantal	Opmerkingen
	NATO Stocknummer	Fbr C nr	Fabrieksartikelnummer			
	1	2	2a			
			3	4	5	
1				SMEERKAART, SK9-329	1	DKMG/SBG
2	7510-17-036-4224	H0711	21.6096	SYSTEEMBAND, LOSSE BLADEN	1	i

Detaillijst NSN 2330-17-022-0065

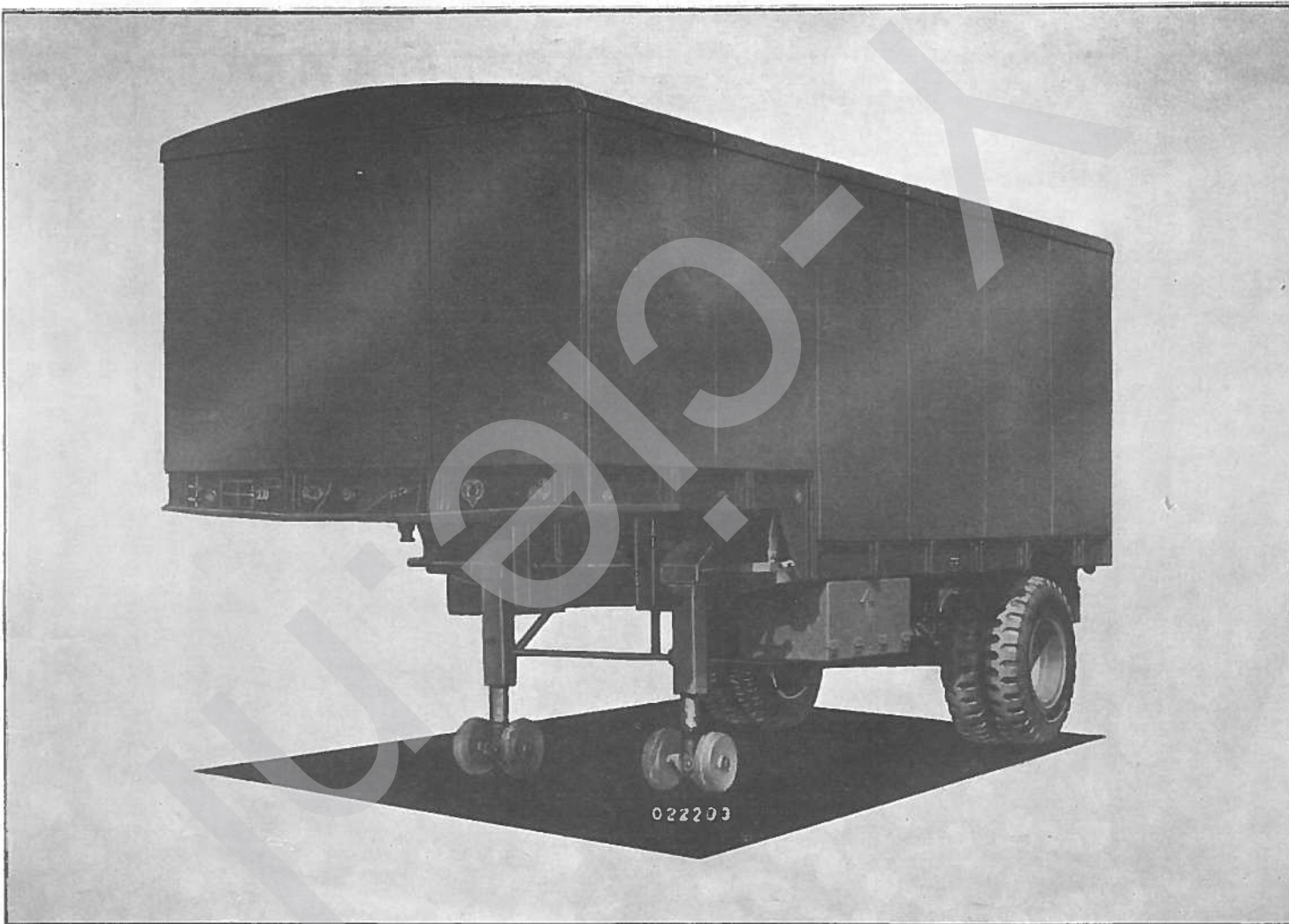

LINKER VOOR ZIJAANZICHT OPLEGGER, GESLOTEN OPBOUW 6 TON, 2 WIELEN, DL, YAA 602 (DAF)

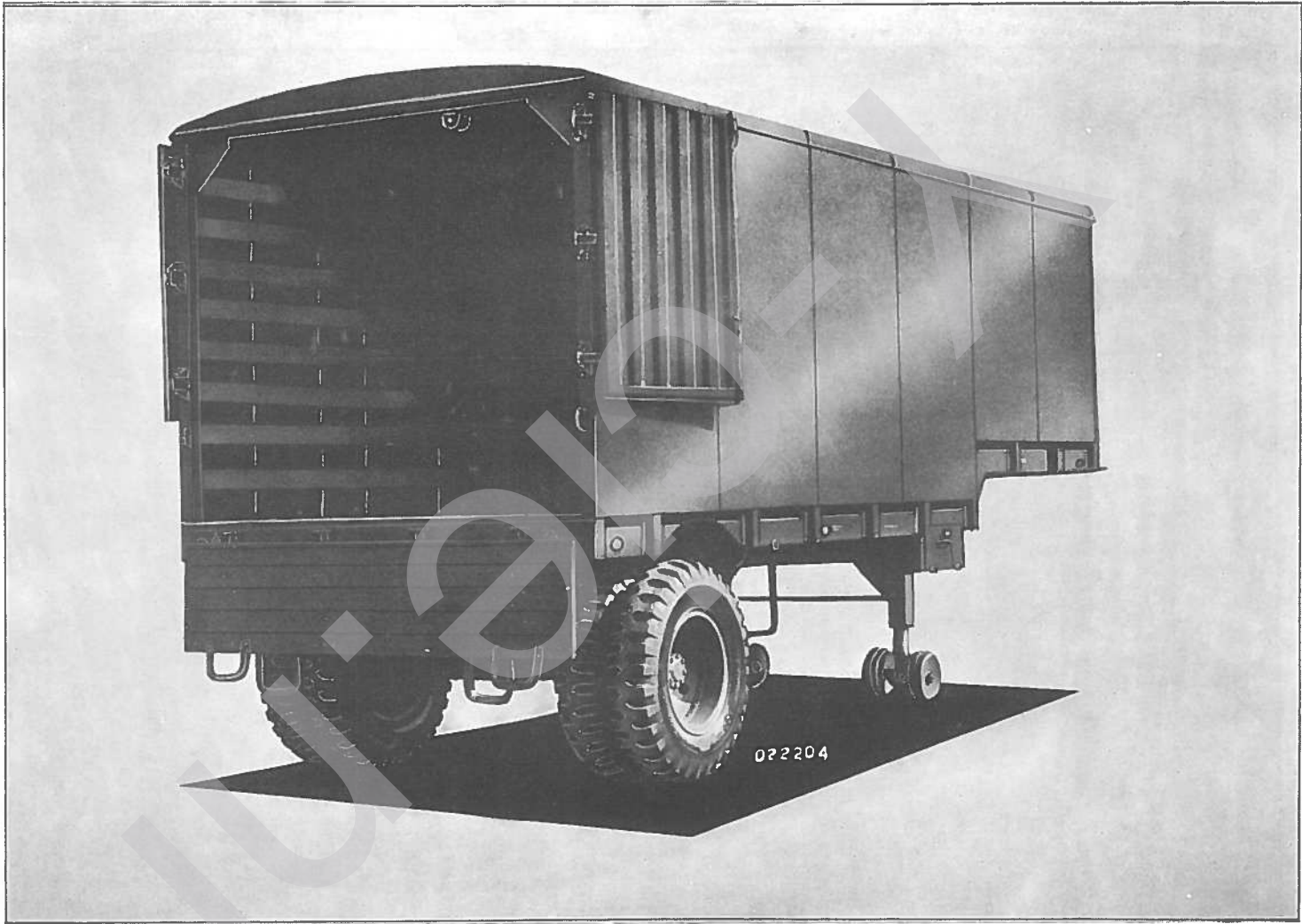

RECHTER ACHTER ZIJAANZICHT OPLEGGER, GESLOTEN OPBOUW 6 TON, 2 WIELEN, DL, YAA 602 (DAF)



LINKER VOOR ZIJAANZICHT OPLEGGER, VRACHT: 6 TON, 2 WIELEN, DL, YAA 612 (DAF)



RECHTER ACHTER ZIJAANZICHT OPLEGGER, VRACHT, 6 TON, 2 WIELEN, DL, YAA 612 (DAF)

DEEL II

Overzicht van de reservedelen, welke voor het veld- en basis-
onderhoud mogen worden aangewend, daarbij aangegeven welke
reservedelen daarvan mogen worden aangewend ten behoeve van
het onderdeelsonderhoud.

Volgnr	Artikelnummer		Artikelomschrijving	aantal gemon- teerd	2e ech	3e ech	4e ech	Opmerkingen
	NATO Stocknummer	Fabrieksnummer						
	1	2						
			GROEP 06 - ELEKTRISCHE INSTALLATIE					
			0608.00 - VERDEELKAST, SMELPATRONEN en CONNECTOR, DOOS, binnenverlichting <u>(alleen voor NSN 2330-17-022-0065)</u>					
1	5935-17-003-3953		CONNECTOR, DOOS, ELEKTRISCH, 3-polig, 110 V aansl (binnenver- lichting)	1		+	+	r
2	5306-17-006-7107		BOUT, ZESKANT, St, 1/4 in x 28 UNF-2A x 5/8 in, vcad	2		+	+	
3	5310-17-017-9933		MOER, ZESKANT, St, 1/4 in x 28 UNF-2B, vcad	2		+	+	
4	5310-17-002-0309		RING, VEER, RECHT, St, 1/4 in, vcad	2		+	+	
5			CONNECTOR, DOOS, ELEKTRISCH, m/aardcontact, 2-polig, 10 A, 250 V (in bergkast accu en gelijkrichter) (H0001/144842)	1		+	+	za
6	5310-17-022-1832		MOER, ZESKANT, St, M 4, vcad	2		+	+	
7	5310-17-006-1854		RING, VEER-, RECHT, St, B 4, gezwart	2		+	+	
8	5305-17-022-8562		SCHROEF, CILINDERKOP, St, M4 x 20, vcad	2		+	+	
9	5999-17-001-3721		KAP, ELEKTRISCH, v/smeltpatroon	3	+	+	+	vbdd
10	5920-17-002-6665		SMELTPATROON, GESLOTEN, 6 A, 500 V	2	+	+	+	vbdd
11	5920-17-002-6666		SMELTPATROON, GESLOTEN, 15 A, 500 V	1	+	+	+	vbdd
12	6110-17-022-2321		VERDEELKAST (binnenverlichting)	1		+	+	r
13	5305-99-941-0529		BOUT, ZESKANT, St, 5/16 in x 24 UNF-2A x 1.1/4 in, vcad	4		+	+	
14	5310-17-026-3972		RING, VEER-, RECHT, St, B 8	4		+	+	
			0609.00 - STADS-, GRENS-, STOP-/ACHTERLAMPEN en HULPLAMPEN					
15	6220-17-025-8349		ARMATUUR, ALGEMEEN, cp1 (oogarmatuur) <u>(alleen voor NSN 2330-17-022-0065)</u>	5		+	+	r

Detaillijst NSN 2330-17-022-0065

Volgnr	Artikelnummer		Artikelomschrijving	aantal gemon- teerd	2e ech	3e ech	4e ech	Opmerkingen
	NATO Stocknummer	Fabrieksnummer						
	1	2						
			GROEP 06 - ELEKTRISCHE INSTALLATIE (vervolg) 0609.00 - STADS-, GRENS-, STOP-/ACHTERLAMPEN en HULPLAMPEN (vervolg)					
1	5306-17-006-7107		BOUT, ZESKANT, St, 1/4 in x 28 UNF-2A x 5/8 in, vcad	10		+	+	
2	5310-17-017-9933		MOER, ZESKANT, St, 1/4 in x 28 UNF-2B, vcad	10		+	+	
3	5310-17-002-0309		RING, VEER-, RECHT, St, 1/4 in, vcad	10		+	+	
4			GLAS, kentekenplaatverlichting (H0001//204361) (D8015//LFE43/3X)	2				
5	6220-17-023-3044		GLAS, STOPLICHT- ACHTERLICHT, m/schroef	2	+	+	+	fig 0601-22
6	6220-17-023-3021		GLAS, ZIJLICHT, stadslicht	2	+	+	+	fig 0601-14
7	6220-17-023-3023		GLAS, ZIJLICHT (verduisterd)	2	+	+	+	fig 0601-27
8	6240-17-024-4082		GLOEILAMP, 6 V, 18 W, lampvoet BA 15S, plafondlicht (alleen voor NSN 2330-17-022-0065)	5	+	+	+	vbdd i
9	6240-17-005-3376		GLOEILAMP, 24 V, 5 W, lampvoet BA 15S 6 - stop-/achterlicht 2 - grenslicht 2 - stadslicht	10	+	+	+	vbdd i
10	6240-17-006-6924		GLOEILAMP, 24 V, 20 W, lampvoet BA 15S, stop-/achterlicht	2	+	+	+	vbdd i
11	6240-17-005-9576		GLOEILAMP, 127 V, 25 W, lampvoet B22, gematteerd (plafond- licht) (alleen voor NSN 2330-17-022-0065)	5	+	+	+	vbdd i
12			HOUDER, GLAS, zijlicht (stadslicht) (H0001//15833) (H1379//P-1360-3)	2				fig 0601-15
13			SCHROEF, CILINDERKOP (H0001//551474)	4				fig 0601-16
14			HOUDER, GLAS, zijlicht (verduisterd) (H0001//347467) (H1379//S-1052)	2				fig 0601-30

Volgnr	Artikelnummer		Artikeleomschrijving	aantal gemon- teerd	2e ech	3e ech	4e ech	Opmerkingen
	NATO Stocknummer	Fabrieksnummer						
	1	2						
1			HOUDER, LAMPHOUDER (H0001//158326) (H1379//S1053) 2 - stadslicht 2 - grenslicht	4				fig 0601-8+23
2			HUIS, stop-/achterlicht (H1379//1320-9)	2				fig 0601-20
3			HUIS, stop-/achterlicht (verduisterd) (H0001//122454) (D8015//Q0129/3)	2				fig 0601-4
4			ISOLATOR, BUS, ru, stads- en grenslichten (H0001//158327)	4				fig 0601-9+24
5			KLEMVEER, glas, kentekenplaatverlichting (D8015//LBF11/2X)	4				
6			LAMPHOUDER, m/contactschroef (H0001//158329) 2 - stadslicht 2 - grenslicht	4				fig 0601-10+25
7			LICHTREFLECTOR, zijlicht (stadslicht) (H0001//158330)	2				fig 0601-12
8	6220-17-023-2944		LICHTSCHEM, LAMP, m/schroef, stop-/achterlicht (verduisterd)	2	+	+	+	fig 0601-6
9	5305-17-017-7404		SCHROEF, BORST, St, M4 x 0.75, spec	2	+	+	+	fig 0601-7
10			LICHTSCHEM, LAMP, zijlicht (verduisterd) (H0009//5338)	2				fig 0601-28
11	6220-17-025-0854		LICHT, STOP-/ACHTER, VOERTUIG, m/kentekenplaatverlichting	2	+	+	+	
12	6220-17-007-1564		LICHT, STOP-/ACHTER, VOERTUIG (verduisterd)	2	+	+	+	
13	5310-17-002-0309		RING, VEER-, RECHT, St, B6, gezwart	8	+	+	+	fig 0601-2+18
14	5305-17-005-3597		SCHROEF, CILINDERKOP, St, AM 6 x 12, vcad	8	+	+	+	fig 0601-1+17
15	6220-17-015-5301		LICHT, ZIJ (stadslicht) (wordt als grenslicht gebruikt)	2	+	+	+	
16	6220-17-023-0552		LICHT, ZIJ (verduisterd)	2	+	+	+	
17			PAKKING, PLAAT, SPECIAAL, glas, kentekenplaatverlichting (D8015//LPT109/2X)	2				
18	5330-17-025-8729		PAKKINGRING, ru, glas, stadslicht	2	+	+	+	fig 0601-13
19			PAKKINGRING, ru, glas, zijlicht (verduisterd) (H0001//563614)	2				fig 0601-29

Volgnr	Artikelnummer		Artikelomschrijving	aantal gemon- teerd	2e ech	3e ech	4e ech	Opmerkingen
	NATO Stocknummer	Fabrieksnummer						
	1	2						
			GROEP 06 - ELEKTRISCHE INSTALLATIE (vervolg)					
			0609.00 - STADS-, GRENS-, STOP-/ACHTERLAMPEN en HULPLAMPEN (vervolg)					
1			SCHROEF, CILINDERKOP, St, M4 x 0.5, vcd, lamphouder, stop-/ achterlamp (D8615//NSR5179/13x843)	8				fig 0601-5+21
2			TULE, RUBBER, stop-/achterlicht (H0001//204208)	4				fig 0601-3+19
3			VEER, DRUK-, SCHROEFVORMIG, zijlicht (stadslicht) (H0001//158328)	2				fig 0601-11
4			VEER, DRUK-, SCHROEFVORMIG, zijlicht (verduisterd) (H0001//324967)	2				fig 0601-26
			0612.00 - ACCU en GELIJKRICHTER (alleen voor NSN 2330-17-022-0065)					
5	5940-17-001-4505		AANSLUITKLEM, KABELSCHOEN, batterij (neg)	1	+	+	+	
6	5940-17-001-4506		AANSLUITKLEM, KABELSCHOEN, batterij (pos)	1	+	+	+	
7	6140-17-025-8169		BATTERIJ, LAADBAAR, lood-zwavelzuur, geladen, 6 V, 120 Ah	1	+	+	+	
8	2590-17-007-6081		BEUGEL, v/bevestigen accu	1				
9	5306-17-004-6957		BOUT, HAAK-, St, accubeugel	2	+	+	+	
10	5365-17-003-4031		BUS, AFSTAND, 11 x 19 x 10 mm	2	+	+	+	
11	5310-17-026-0110		MOER, VLEUGEL, St, 3/8 in x 24 UNF-2B, vcd	2	+	+	+	
12	5306-00-043-2768		BOUT, VIERSKANT, St, 5/16 in x 18 UNC-2A x 1.5/16 in, vld, batterijklem	2	+	+	+	
13	5310-17-015-8974		MOER, ZESKANT, St, 5/16 in x 18 UNC, vld	2	+	+	+	
14	6130-17-707-2699		GELIJKRICHTER, METAAL, ingangsspanning 110/220 V, uitgangs- stroom, 6 V-15 A, 6 V-3 A, 12 V-1 A en 12 V-2 A, v/h opladen van batterijen	1	+	+	+	

Volgnr	Artikelnummer		Artikelomschrijving	aantal gemon- teerd	2e ech	3e ech	4e ech	Opmerkingen
	NATO Stocknummer	Fabrieksnummer						
	1	2						
3	4	5	6	7	8			
1	5640-17-003-4679		ISOLATIE KOUS, THERMISCH, 2 mm ID, L 240 mm (drukveer gelijk-richter)	1	+	+	+	
2	5330-17-004-8950		VILT, TECHNISCH, VOORGEVORMD, 16 x 35 x 4.2 mm, batterijpool	2	+	+	+	
3	5340-17-004-5462		VEER, DRUK-, SCHROEFVORMIG, gelijkrichter (tussen lamp en deksel)	1	+	+	+	
4	5360-17-004-5840		VEER, TREK-, SCHROEFVORMIG, v/opanging raam gelijkrichter	10	+	+	+	
5	5360-17-004-5839		VEER, TREK-, SCHROEFVORMIG, v/opsluiten gelijkrichter in raam	2	+	+	+	
6	8305-17-024-2033		VILTSTROOK, 15 mm x 2 mm (L 140 mm) (gelijkrichterhuis)	nb	+	+	+	per meter
7	6810-17-003-3666		ZWAVELZUUR, BATTERIJ, VERDUND, sg 1.280 (in mandflessen van 25 liter)	nb	+	+	+	int
			0613,00 - BEDRADING					
8	5940-17-003-7142		AANSLUITKLEM, KABELSCHOEN, mess, 5.5 mm ID, v/1.5 mm ² kabel, vtin	2		+	+	
9	5940-17-003-7143		AANSLUITKLEM, KABELSCHOEN, mess, 6.5 mm ID, v/1.5 mm ² kabel, vtin	2		+	+	
10	5940-17-709-1789		AANSLUITKLEM, KABELSCHOEN, mess, 6.5 mm ID, v/4 mm ² kabel	2		+	+	
11	5940-17-023-0557		AANSLUITSTROOK, plastic of ru, min 4 aansl (in blokken van 3 stuks) (op lengte afzagen naar behoefte)	2		+	+	
12	5310-17-022-1832		MOER, ZESKANT, St, M4, vcad	10		+	+	
13	5310-17-631-6450		RING, SLUIT-, St, 5 x 10 x 0.8 mm, vcad	3		+	+	
14	5310-17-006-1854		RING, VEER, RECHT, St, B4, gezwart	10		+	+	
15	5305-17-022-8562		SCHROEF, CILINDERKOP, St, M4 x 20, vcad	12		+	+	
16	5440-17-015-1046		BEUGEL, INSTALLATIE, halfzadel, St, voor 16 mm pijp (doorvoerpijpen)	52		+	+	
17	5306-17-007-7520		BOUT, ZESKANT, St, 1/4 in x 28 UNF-2A x 1/2 in, vcad	52		+	+	

Volgnr	Artikelnummer		Artikelomschrijving	aantal gemen- teerd	2e ech	3e ech	4e ech	Opmerkingen
	NATO Stocknummer	Fabrieksnummer						
	1	2						
			GROEP 06 - ELEKTRISCHE INSTALLATIE (vervolg) 0613.00 - BEDRADING (vervolg)					
1	5310-17-002-0309		RING, VEER-, RECHT, St, 1/4 in, vcad	52		+	+	
2	5340-17-017-4581		BEUGEL, INSTALLATIE, voor 2 maal 16 mm pijp (doorvoerpijpen)	8		+	+	
3	5306-17-006-7107		BOUT, ZESKANT, St, 1/4 in x 28 UNF-2A x 5/8 in, vcad	8		+	+	
4	5310-17-002-0309		RING, VEER-, RECHT, St, 1/4 in, vcad	8		+	+	
5			DEKSEL, verdeeldoos	2				
6	5305-17-003-5787		SCHROEF, CILINDERKOP, St, AM4 x 10, vcad	12		+	+	
7	6145-17-001-9627		DRAAD, ELEKTRISCH, 1-ad, nr 12 AWG, 0.235 in UD, L 200 mm	nb		+	+	per meter
8	6145-17-006-2525		DRAAD, ELEKTRISCH, 1-ad, 1.5 mm ² , zwart bedr buitenverlichting, L 70.000 mm bedr binnenverlichting, L 50.000 mm	nb		+	+	per meter
9			INSTALLATIEDOOS, ELEKTRISCHE LEIDING, 3-weg-dubbel re, in bergkast accu en gelijkrichter (alleen voor NSN 2330-17-022-0065)	1				
10	5306-17-007-7520		BOUT, ZESKANT, St, 1/4 in x 28 UNF-2A x 1/2 in, vcad	1		+	+	
11	5310-17-017-9933		MOER, ZESKANT, St, 1/4 in x 28 UNF-2B, vcad	1		+	+	
12	5310-17-002-0309		RING, VEER-, RECHT, St, 1/4 in, vcad	1		+	+	
13	5970-17-026-1160		ISOLATIEBUIS, ELEKTRISCH, plastic, 8 mm, zwart (L 9500 mm)	nb		+	+	per meter
14	5975-17-022-2402		ISOLATIETULE, ELEKTRISCH, 5-weg, 15 mm ID (doorvoerpijp)	5		+	+	
15	6145-17-005-2928		KABEL, VOEDING, ELEKTRISCH, 2 x 1.5 mm ² , zwart (bedr binnenverlichting), L 2500 mm	nb		+	+	per meter
16	6145-17-025-0979		KABEL, SPECIAAL, ELEKTRISCH, 3-ad, 1.5 mm ² (bedr binnenverlichting), L 2500 mm	nb		+	+	per meter
17	5975-17-640-0025		LEIDING, St, flex, 13 mm ID, 16 mm UD, gegal (doorvoer bedr binnenverlichting)	nb		+	+	per meter

- 14 -
- (2e verv) -

W 7

Detaillijst NSN 2330-17-022-0065

Volgnr	Artikelnummer		Artikelomschrijving	aantal gemon- teerd	2e ech	3e ech	4e ech	Opmerkingen
	NATO Stocknummer	Fabrieksnummer						
	1	2						
1	5975-17-004-5842		MERKTULE, ELEKTRISCHE KABEL, nr 056 (4 mm ID)	3		+	+	
2	5975-17-004-5841		MERKTULE, ELEKTRISCHE KABEL, nr 057 (4 mm ID)	2		+	+	
3	5975-17-022-0960		MERKTULE, ELEKTRISCHE KABEL, nr 073 (4 mm ID)	12		+	+	
4	5975-17-022-0959		MERKTULE, ELEKTRISCHE KABEL, nr 074 (4 mm ID)	12		+	+	
5	5975-17-003-7147		MERKTULE, ELEKTRISCHE KABEL, nr 56 (4 mm ID)	1		+	+	
6	5975-17-003-7145		MERKTULE, ELEKTRISCHE KABEL, nr 57 (4 mm ID)	2		+	+	
7	5975-17-003-7144		MERKTULE, ELEKTRISCHE KABEL, nr 58 (4 mm ID)	4		+	+	
8	5975-17-003-7229		MERKTULE, ELEKTRISCHE KABEL, nr 59 (4 mm ID)	9		+	+	
9	5975-17-004-5843		MERKTULE, ELEKTRISCHE KABEL, nr 6/1 (4 mm ID) (bedr binnen- verlichting)	11		+	+	
10	5975-17-004-5851		MERKTULE, ELEKTRISCHE KABEL, nr 6/2 (4 mm ID) (bedr binnen- verlichting)	11		+	+	
11	5975-17-022-1926		MERKTULE, ELEKTRISCHE KABEL, nr 90 (4 mm ID)	2		+	+	
12	5975-17-003-7177		MERKTULE, ELEKTRISCHE KABEL, nr 580 (4 mm ID)	2		+	+	
13	5975-17-003-7167		MERKTULE, ELEKTRISCHE KABEL, nr 581 (4 mm ID)	2		+	+	
14	5975-17-003-7176		MERKTULE, ELEKTRISCHE KABEL, nr 585 (4 mm ID)	5		+	+	
15	5975-17-003-7175		MERKTULE, ELEKTRISCHE KABEL, nr 586 (4 mm ID)	2		+	+	
16	5975-17-003-7166		MERKTULE, ELEKTRISCHE KABEL, nr 591 (4 mm ID)	2		+	+	
17	5975-17-003-7174		MERKTULE, ELEKTRISCHE KABEL, nr 595 (4 mm ID)	5		+	+	
18	5975-17-003-7169		MERKTULE, ELEKTRISCHE KABEL, nr 596 (4 mm ID)	5		+	+	
19	5975-17-004-5848		MERKTULE, ELEKTRISCHE KABEL, nr 110/1 (4 mm ID) (bedr binnen- verlichting)	11		+	+	
20	5975-17-004-5849		MERKTULE, ELEKTRISCHE KABEL, nr 110/2 (4 mm ID) (bedr binnen- verlichting)	11		+	+	
21	5975-17-004-5850		MERKTULE, ELEKTRISCHE KABEL, nr 110/3 (4 mm ID) (bedr binnen- verlichting)	8		+	+	

Volgnr	Artikelnummer		Artikelomschrijving	aantal gemon- teerd	2e ech	3e ech	4e ech	Opmerkingen
	NATO Stocknummer	Fabrieksnummer						
	1	2						
			GROEP 06 - ELEKTRISCHE INSTALLATIE (vervolg)					
			0613.00 - BEDRADING (vervolg)					
1	5330-17-003-3974		PAKKING, PLAAT, SPECIAAL, ru, deksel verdeeldoos	2		+	+	
2	5975-17-003-3952		PAKKINGBUS, m/zesk, St, verdeeldoos	5				
3	5330-17-003-4297		PAKKINGRING, prespaan, 17 x 26 x 1 mm, doorvoer verdeeldoos	5		+	+	
4	5325-17-616-7076		TULE, BLIND, NIET-METAAL, 18 x 30 mm (v/afdichten gat ver- duisterfngsschakelaar)	1		+	+	
5	5325-17-004-7249		TULE, RUBBER, 8 x 14 x 6 mm, verdeeldoos	2		+	+	
6	5325-17-004-7248		TULE, RUBBER, 8 x 23 x 16 mm (bedr plafondlamp). (alleen voor NSN 2330-17-022-0065)	10		+	+	
7	5325-17-004-7230		TULE, RUBBER, 10 x 19 x 8 mm, grenslamp	4		+	+	
8	5325-17-004-7244		TULE, RUBBER, 15 x 30 x 10 mm, verdeeldoos	2		+	+	
			0613.50 - VOLGWAGENKOPPELING					
9	5935-00-846-3884		CONNECTOR, DOOS, ELEKTRISCH, m/deksel, 12-polig	1		+	+	
10	5306-17-007-7523		BOUT, ZESKANT, St, 1/4 in x 28 UNF-2A x 7/8 in, vcad	4		+	+	
11	5310-17-017-9933		MOER, ZESKANT, St, 1/4 in x 28 UNF-2B, vcad	4		+	+	
12	5310-17-002-0309		RING, VEER-, RECHT, St, 1/4 in, vcad	4		+	+	
13			MONTAGEPLAAT, v/12-polige connectordoos (H0711//4050)	1				
14	5306-17-007-7523		BOUT, ZESKANT, St, 1/4 in x 28 UNF-2A x 7/8 in, vcad	4		+	+	
15	5310-17-017-9933		MOER, ZESKANT, St, 1/4 in x 28 UNF-2B, vcad	4		+	+	
16	5310-17-002-0309		RING, VEER-, RECHT, St, 1/4 in, vcad	4		+	+	

Volgnr	Artikelnummer		Artikelomschrijving	aantal gemon- teerd	2e ech	3e ech	4e ech	Opmerkingen
	NATO Stocknummer	Fabrieksnummer						
	1	2						
			GROEP 11 - AS 1100.00 - AS, cp1					
1	2530-17-004-6253		AS, VOERTUIG, NIET-AANDRIJVEND, m/naven en remtrommels (geheel bedrijfsklaar)	1	1%	+	+	r
			1101.00 - ASLICHAAM					
2	2530-17-004-6250		AS, VOERTUIG, NIET-AANDRIJVEND	1				
			GROEP 12 - REMINSTALLATIE 1201.00 - HANDREMINSTALLATIE					
3	⁵³⁶⁵ 5340 -17-001-3826		BORGRING, uitw, type "SEEGER", St, 25 x 1.2 mm, gefosf, hefboomsarm/remevenaar	1		+	+	
4	⁵³⁶⁵ 5340 -17-003-1891		BORGRING, uitw, type "SEEGER", St, 30 x 1.5 mm, gefosf, remevenaar/as	1		+	+	
5			DEKSEL, DRAADSPILHUIS (H0001//149123)	1				fig 1201-11
6	5306-17-003-6349		BOUT, ZESKANT, St, M5 x 10, vcad	2		+	+	fig 1201-13
7	5310-17-017-6308		RING, VEER-, GETAND, uitw, St, A5.3, gezwart	2		+	+	fig 1201-12
8	5305-17-017-4696		SCHROEF, PLAAT, St, nr 6 x 1/2 in	6		+	+	fig 1201-10
9	2530-17-007-6073		DRAADSPIL, 19 x 245 mm, staalkabel	1		+	+	fig 1201-5
10	5340-17-004-6887		GAFFEL, STANGEIND, St, kabel/draadspil	1		+	+	fig 1201-7
11	5310-17-017-2426		MOER, KROON, zesk, kroon in het zeskant, St, 1/2 in x 20 UNF-2B, vcad	1		+	+	fig 1201-6
12	5315-17-001-6676		PEN, SPLIT, St, 4 x 40 mm, gefosf	1		+	+	
13	5310-17-003-6143		RING, SLUIT-, St, 13.5 x 21 x 2 mm, vcad	1		+	+	
14	2520-17-002-2787		GAFFEL, STANGEIND, St, trekstang	4		+	+	

Volgnr	Artikelnummer		Artikelomschrijving	aantal geman- teerd	2e ech	3e ech	4e ech	Opmerkingen
	NATO Stocknummer	Fabrieksnummer						
	1	2						
			GROEP 12 - REMINSTALLATIE (vervolg) 1201.00 - HANDREMINSTALLATIE (vervolg)					
1	5310-17-017-9932		MOER, ZESKANT, St, 1/2 in x 20 UNF - 2B, vcad	4		+	+	
2	2530-17-017-3543		HEFBOOMSARM, AFSTANDBEDIENING, m/lagerbus	1		+	+	
3	2530-17-017-3550		HEFBOOMSARM, AFSTANDBEDIENING, m/lagerbus, reeveenaar	1		+	+	
4	4010-17-024-2162		KABEL, STAALDRAAD, 5/16 in (L ± 1850 mm)	1	+	+	+	fig 1201-16
5	4030-17-026-1233		KLEM, KABEL, St, 5/16 in, gegalv	4	+	+	+	fig 1201-15
6	5340-17-007-6291		KLEM, VEER-, slinger (ruststand)	1	+	+	+	fig 1201-1
7	5306-17-006-7107		BOUT, ZESKANT, St, 1/4 in x 28 UNF - 2A x 5/8 in, vcad	2	+	+	+	
8	5310-17-015-8546		MOER, ZESKANT, laag, St, 1/4 in x 28 UNF - 2B, vcad	2	+	+	+	
9	5310-17-002-0309		RING, VEER-, RECHT, St, 1/4 in	2	+	+	+	
10	4030-17-025-9601		KOUS, TUIGAGE, gegalv, 5/16 in (staaldraadkabel)	2	+	+	+	fig 1201-14
11	2530-17-006-8725		KRUK, HAND, v/bediening handrem	1	+	+	+	fig 1201-2
12	5306-17-015-9041		BOUT, ZESKANT, St, 5/16 x 24 UNF - 2A x 1.3/4 in, vcad	1	+	+	+	fig 1201-3
13	5310-17-001-7712		MOER, KROON, zesk, kroon in het zeskant, St, 5/16 in x 24 UNF - 2B, vcad	1	+	+	+	fig 1201-4
14	5315-17-001-6639		PEN, SPLIT, St, 2 x 20 mm, gefosf	1	+	+	+	
15	5310-17-003-8217		RING, SLUIT-, St, 8.4 x 17 x 2 mm, vcad	1	+	+	+	
16	3120-17-001-8330		LAGER, GLIJ-, BUS, nylon, 10 x 14 x 12 mm, reeveenaar hefboomsarm/kop-pen	3		+	+	
17	3120-17-015-0580		LAGER, GLIJ-, BUS, nylon, 25 x 30 x 25 mm, hefboomsarm, evenaar	1		+	+	
18	3120-17-015-0582		LAGER, GLIJ-, BUS, nylon, 30 x 35 x 30 mm, reeveenaar	1		+	+	

Volgnr	Artikelnummer		Artikelo omschrijving	aantal gemon- teerd	2e ech	3e ech	4e ech	Opmerkingen
	NATO Stocknummer	Fabrieksnummer						
	1	2						
1	5315-17-004-7253		PEN, CILINDRISCH, MET KOP, St, 10 x 32 x 28 mm remhefboom/verbindingsstrip gaffel/trekstang	5	+	+	+	fig 1201-22
2	5315-17-001-6660		PEN, SPLIT, St, 3 x 20 mm, gefosf	4	+	+	+	
3	5315-17-001-6664		PEN, SPLIT, St, 3 x 30 mm, gefosf	1	+	+	+	
4	5310-17-003-6145		RING, SLUIT-, St, 10,5 x 18 x 1,5 mm, vcad	4	+	+	+	
5	5310-17-003-1142		RING, SLUIT-, St, 10,5 x 21 x 2,5 mm, vcad	1	+	+	+	
6	5315-17-003-6183		PEN, CILINDRISCH, MET KOP, 12h11 x 35 x 30 mm, vcad, riem- schijf	1		+	+	fig 1201-19
7	5315-17-001-6675		PEN, SPLIT, St, 4 x 30 mm, gefosf	1		+	+	
8	5310-17-003-6147		RING, SLUIT-, St, 13 x 20 x 2 mm, vcad	1		+	+	
9	5315-17-003-6182		PEN, CILINDRISCH, MET KOP, St, 14h11 x 60 x 55 mm, vcad, gaffel, kabel/draadspil	1	+	+	+	fig 1201-8
10	5315-17-001-6675		PEN, SPLIT, St, 4 x 30 mm, gefosf	1	+	+	+	
11	5310-17-003-6144		RING, SLUIT-, St, 15 x 25 x 2 mm, vcad	1	+	+	+	fig 1201-9
12	3020-17-003-4692		RIEMSCHIJF, GEGROEFD	1		+	+	fig 1201-18
13	5310-17-003-7544		RING, SLUIT-, St, 26 x 40 x 4 mm, vcad, hefboomsarm/rem- evenaar	1		+	+	
14	5310-17-003-7283		RING, SLUIT-, St, 31 x 50 x 4 mm, vcad, hefboomsarm/rem- evenaar	1		+	+	
15	4030-17-015-0296		SLUITING, type IX, "D", St, 6 mm dik, beenwijdte 11 mm, vcad (verbindingsstrip/staalkabel)	1	+	+	+	fig 1201-20
16	5315-17-001-6639		PEN, SPLIT, St, 2 x 20 mm, gefosf	1	+	+	+	
17	5306-17-007-6076		TREKSTANG, evenaar/hefboom wielremcilinder	2				
18			VERBINDINGSSTRIP, ST (H0001//149720)	1				fig 1201-21

Volgnr	Artikelnummer		Artikeloomschrijving	aantal gemon- teerd	2e ech	3e ech	4e ech	Opmerkingen
	NATO Stocknummer	Fabrieksnummer						
	1	2						
			GROEP 12 - REMINSTALLATIE (vervolg) 1202.00 - WIELREINSTALLATIE					
1	2530-17-611-5619		AANSLAGPEN, stelsegment	2		+	+	fig 1202-19
2	2530-17-611-5618		AS, GETRAPT, v/centreren remschoen (bo)	2		+	+	fig 1202-27
3	2530-17-611-5600		AS, GETRAPT, v/centreren remschoen (ond)	2		+	+	fig 1202-23
4	5310-17-015-8581		MOER, ZESKANT, laag, St, 1/2 in x 20 UNF - 2B, vcad	4		+	+	fig 1202-24
5	5310-17-015-1358		MOER, ZESKANT, ZELFBORGEND, laag, type "SIMMONDS", St, 7/16 in x 20 UNF - 2B, vcad	4	+	+	+	fig 1202-21
6	2530-17-611-5596	29 000-3603	BORGPLAAT, St, pen, segment, expansiehuis	4		+	+	fig 1202-38
7	5340-17-015-0310		BORGRING, uitw, type "SEGER", St, stelbout/stofdeksel	4		+	+	fig 1202-1
8	5306-17-706-2177		BOUT, STEL-, remschoen	4		+	+	fig 1202-5
9	5306-17-611-5670		BOUT, ZESKANT, St, v/begrenzen expansiestuk, m/kraag (in expansiehuis)	2			+	fig 1202-34
10	2530-17-015-5165		EXPANSIEHUIS, cpl, wielremcilinder	2	%%	+	+	
11	2530-17-015-5172		EXPANSIESTUK, St, expansiehuis/remschoen	2			+	fig 1202-30
12	2530-17-015-5100		EXPANSIESTUK, St, m/kraag, expansiehuis/remschoen	2			+	fig 1202-32
13	2530-17-611-5594		GAFFEL, segment, expansiestuk/expansiehuis	2			+	fig 1202-40
14	3110-17-022-1081		KOGEL, LAGER, St, 1/4 in, stelbout	8		+	+	fig 1202-6
15	5330-17-017-4602		PAKKING, FLENS, vetkeerplaat, remankerplaat	2		+	+	fig 1301-3
16	5315-17-611-5672		PEN, CILINDRISCH, brons, gaffel/segment, expansiehuis	2			+	fig 1202-39
17	5315-17-611-5620		PEN, CILINDRISCH, v/aanslag drukveer, gaffel/expansiehuis	2			+	fig 1202-35
18	5315-17-611-5621		PEN, CILINDRISCH, v/aanslag segment, gaffel/expansiehuis	2			+	fig 1202-41
19	2530-17-015-5156		REMANKERPLAAT, li	1		+	+	fig 1202-25

Volgnr	Artikelnummer		Artikelomschrijving	aantal gemon- teerd	2e ech	3e ech	4e ech	Opmerkingen
	NATO Stocknummer	Fabrieksnummer						
	1	2						
1	2530-17-015-5145		REMANKERPLAAT, re	1		+	+	fig 1202-25
2	5306-17-007-7552		BOUT, ZESKANT, St, 7/16 in x 20 UNF - 2A x 1.1/4 in, vcad	20		+	+	
3	5310-17-017-0230		MOER, ZESKANT, St, 7/16 in x 20 UNF - 2B, vcad	20		+	+	
4	5310-17-003-7978		RING, VEER-, RECHT, St, B12	20		+	+	
5	2530-17-611-5562		REMSCHOEN, INWENDIGE WERKING, m/voering	4	100%	+	+	fig 1202-18 r
6	2530-17-022-6597		REMOVINGPAKKET	nb		+	+	
			<u>artikelomschrijving samengesteld artikel:</u>					
7	5320-17-003-6729		64 - NAGEL, KLINK, HOL			+	+	
8	2530-17-024-6774		4 - VOERING, FRICTIE			+	+	
9	2530-17-611-5597		RING, SLUIT-, kogel, stelbout	4		+	+	
10	5310-17-611-5666		RING, SLUIT-, St, centreeras (bo)	4		+	+	fig 1202-26
11	5310-17-611-5660		RING, SLUIT-, St, centreeras (ond)	4		+	+	fig 1202-22
12	2530-17-015-0317		SEGMENT, expansiestuk, expansiehuis	4			+	fig 1202-36
13	2530-17-015-0325		STELSEGMENT, remschoen	2		+	+	fig 1202-20
14	2530-17-015-0327		STOFDEKSEL, stelboutveer	4		+	+	fig 1202-2
15	5340-17-611-5671		VEER, DRUK-, SCHROEFVORMIG, gaffel/expansiehuis	2			+	fig 1202-37
16	5340-17-611-5676		VEER, DRUK-, SCHROEFVORMIG, stelbout	4		+	+	fig 1202-3
17	5340-17-611-5665		VEER, TREK-, SCHROEFVORMIG, REMSCHOEN (achter)	2	100%	+	+	fig 1202-17
18	5360-17-611-5669		VEER, TREK-, SCHROEFVORMIG, remschoen (vóór)	2	100%	+	+	fig 1202-28
19	2530-17-022-4660		VETKEERPLAAT, St, remankerplaat	2		+	+	fig 1301-2
			1204.10 - HOOFDREMCIJLINDER en REMVLOEISTOFTANK					
20			AANPASSTUK, hoofdremcilinder/steun (H0001//149471)	1				fig 1203-19

Volgnr	Artikelnummer		Artikelo omschrijving	aantal gomon- teerd	2e ech	3e ech	4e ech	Opmerkingen
	NATO Stocknummer	Fabrieksnummer						
	1	2						
			GROEP 12 - REMINSTALLATIE (vervolg)					
			1204.10 - HOOFDREMCILINDER en REMVLOEISTOFTANK (vervolg)					
1	5306-17-022-0702		BOUT, ZESKANT, St, m/gleuf, 3/8 in x 16 UNC - 2A x 1.1/4 in, vcad	3		+	+	fig 1203-28
2	5310-17-003-7979		RING, VEER-, RECHT, St, B10	3		+	+	fig 1203-27
3	2530-17-611-5462		CILINDERSAMENSTEL, HYDRAULISCHE REM, HOOFD	1	1/2	+	+	
4	5306-17-015-9058		BOUT, ZESKANT, St, 3/8 in x 24 UNF - 2A x 1.1/2 in, vcad	2	+	+	+	fig 1203-39
5	5306-17-007-7568		BOUT, ZESKANT, St, 5/8 in x 18 UNF - 2A x 1.1/2 in, vcad	1	+	+	+	fig 1203-37
6	5310-17-003-7979		RING, VEER-, RECHT, St, B10	2	+	+	+	fig 1203-27
7	5310-17-707-1151		RING, VEER-, RECHT, St, B16	1	+	+	+	fig 1203-22
8	2530-17-611-5605		DEKSEL, TANK, OLIE, HYDRAULISCH SYSTEEM, m/ketting	1	+	+	+	fig 1203-53
9	4730-17-003-5944		KOPPELSTUK, PIJP, 1 in en 1/2 in x 20 NF - 2, hoofdremlin- der/remvloestoftank	1	1/2	+	+	fig 1203-47
10			MANCHET, HYDRAULISCHE REMCILINDER, hoofdremlin- der (H0001//132690)	1				fig 1203-32
11	2530-17-707-4258		MANCHET, HYDRAULISCHE REMCILINDER, zuiger, hoofdremlin- der	1		+	+	
12			MANCHET, HYDRAULISCHE REMCILINDER, zuigerklep, hoofdremlin- der (H0001//304957)	1				
13	2530-17-023-0944		ONDERDELENIUTRUSTING, CILINDERSAMENSTEL, HYDRAULISCHE REM, HOOFD	nb		+	+	
			<u>artikelo omschrijving samengesteld artikel:</u>					
14	2530-17-611-5585		1 - BESCHERMHOES, STOF EN VOCHT			+	+	
15			1 - MANCHET, HYDRAULISCHE REMCILINDER (H0001//132690)					
16	2530-17-707-4258		1 - MANCHET, HYDRAULISCHE REMCILINDER			+	+	
17			1 - RING, DUBBEL CONISCH (H0001//132681)					
18			1 - RING, ru (H0001//304957)					
19	5305-00-361-5112		ONTLUCHTINGSNIPPEL, HYDRAULISCHE REM, hoofdremlin- der	1	*	+	+	fig 1203-45

Volgnr	Artikelnummer		Artikeloomschrijving	aantal gemon- teerd	2e ech	3e ech	4e ech	Opmerkingen
	NATO Stocknummer	Fabrieksnummer						
	1	2						
3	4	5	6	7	8			
1	2530-17-611-5568		REMSTELINRICHTING, cpl	2	1/2	+	+	r
2	5306-17-007-7541		BOUT, ZESKANT, St, 3/8 in x 24 UNF-2A x 7/8 in, vcad	8	+	+	+	fig 1202-8
3	2530-99-800-3451		PLAAT, BORG-, BOUT EN MOER	4	+	+	+	fig 1202-7
4	2530-17-015-0346		SCHOTEL, SCHROEFVORMIGE DRUKVEER, fiber, drukveer/hydr manch- chet, wielremcilinder	2			+	fig 1202-47
5	5340-17-611-5668		VEER, DRUK-, SCHROEFVORMIG, hydr manch	2			+	fig 1202-48
6	5340-17-611-5664		VEER, DRUK-, SCHROEFVORMIG, wielremstelhuis	2			+	fig 1202-11
7	2530-17-611-5593		ZUIGER, HYDRAULISCHE REM, WIELCILINDER, St (gaffelzijde)	2			+	fig 1202-44
8	2530-17-027-7647		ZUIGER, HYDRAULISCHE REM, WIELCILINDER, St (hydr manchetzij- de)	2			+	fig 1202-45
			1204.50 - HYDRAULISCHE LEIDINGEN en AANSLUITINGEN					
9	4730-17-007-6546		DRAADDRUKSTUK, PIJP, 7/16 in x 20 NFS, uitw drd, v/ 1/4 in pijp	4	+	+	+	
10	5340-17-003-6735		KLEM, LUS, strop, St, 8 mm, vcad, leiding kruisstuk/wielrem- cilinder	3	+	+	+	
11	5340-17-003-6733		KLEM, LUS, strop, St, 12 mm, vcad, leiding hoofdremcilinder/ slangsamstel	3	+	+	+	
12	5306-17-015-9047		BOUT, ZESKANT, St, 1/4 in x 28 UNF-2A x 3/8 in, vcad	6	+	+	+	
13	5310-17-002-0309		RING, VEER-, RECHT, St, 1/4 in, vcad	6	+	+	+	
14	4730-17-003-6710		NIPPEL, PIJP, m/zeskant, uitw drd, mess, 1/2 in x 20 NF, v/ 5/16 in pijp, hoofdremcilinder/slangsamstel	1	+	+	+	fig 1203-43
15	5330-17-003-7346		PAKKINGRING, cu, 11.2 x 17.5 x 1.5 mm, slangsamstel	1	+	+	+	
16	4710-17-017-0154		PIJP, KOPER, 1/4 in UD, wanddikte 0.030 in kruisstuk/wielremcilinder, li (L 520 mm) kruisstuk/wielremcilinder, re (L 980 mm)	nb	+	+	+	per foot

Volgnr	Artikelnummer		Artikeloomschrijving	aantal gemon- teerd	2e ech	3e ech	4e ech	Opmerkingen
	NATO Stocknummer	Fabrieksnummer						
	1	2						
			GROEP 12 - REMINSTALLATIE (vervolg)					
			1204.50 - HYDRAULISCHE LEIDINGEN en AANSLUITINGEN (vervolg)					
1	4710-00-277-5526		PIJP, KOPER, 5/16 in UD, wanddikte 0.035 in (L1450 mm), hoofdremcilinder/slangsamensel	nb	+	+	+	per foot
2	2530-17-001-8163		SLANGSAMENSTEL, RUBBER, 7/16 in x 20 NFS en 1/2 in x 20 NFS L 23 in), leiding hoofdremcilinder/kruisstuk	1	+	+	+	
3	5310-17-015-8581		MOER, ZESKANT, laag, St, 1/2 in x 20 UNF-2B, vcad	1	+	+	+	
4	5310-17-003-7984		RING, VEER-, RECHT, St, B 14	1	+	+	+	
5	4730-17-611-5626		T-STUK, PIJP, inw drd, mess, 7/16 in x 20 NFS, v/2 maal 6 mm pijp en 1 maal slangsamensel	1	+	+	+	
6	5310-17-024-2958		MOER, ZESKANT, St, 3/8 in x 24 UNF-2B, vcad	1	+	+	+	
7	5310-17-015-1324		MOER, ZESKANT, St, 3/8 in BSF, vzin	1	+	+	+	
8	5307-17-023-4169		TAPEIND, CILINDRISCH, haaks, St, 3/8 in x 24 UNF-2 en 3/8 in BSF	1	+	+	+	
9	8305-17-024-2033		VILTSTROOK, 15 x 2 mm, (L 180 mm), klem, lus	nb	+	+	+	per meter
10	4730-17-015-1993		WARTELMOER, PIJPKOPPELSTUK, St, v/ 5/16 in pijp, vcad	2	+	+	+	
			1208.00 - REMBEKRACHTIGER					
11	2530-17-007-6082		DEKSEL, membraanhuis	1			+	fig 1203-5
12			DRUKSTANG, HYDRAULISCHE REM, HOOFDCILINDER (H0001//149405)	1				fig 1203-10
13	2530-17-007-2483		HUIS, membraan	1			+	fig 1203-15
14	5310-17-015-7626		MOER, ZESKANT, St, 5/8 in x 18 UNF-2B, vcad	2			+	fig 1203-23
15	5310-17-707-1151		RING, VEER-, RECHT, St, B 16	2			+	fig 1203-22
16	5307-17-600-2318		TAPEIND, CILINDRISCH, St, 5/8 in x 18 UNF (5/16 in) en 5/8 in x 11 UNSS (13/16 in) x 2 in	1			+	fig 1203-21

Volgnr	Artikelnummer		Artikei omschrijving	aantal geman- teerd	2e ech	3e ech	4e ech	Opmerkingen	
	NATO Stocknummer	Fabrieksnummer							
	1	2							
1	5307-17-600-2317		TAPEIND, CILINDRISCH, St, 5/8 in x 18 UNF (15/16 in) en 5/8 in x 11 UNSS (13/16 in) x 2 in (doorboord)	1			+	fig 1203-24	
2	5340-17-600-2315		KLEM, LUS, St, dekse1/membraanhuis	1			+	fig 1203-13	
3	5306-17-600-2316		BOUT, ZESKANT, St, 5/16 in x 24 UNF-2A x 1.1/16 in	2			+	fig 1203-14	
4	5310-17-017-9937		MOER, ZESKANT, St, 5/16 in x 24 UNF-2B, vcad	2			+	fig 1203-12	
5	4730-17-600-2320		KNIE, PIJP, mess, in- en uitw drd, 1/8 in NPT en 1/4 in NPT, v/aansluiting ontluchter	1			+	+	fig 1203-25
6	2530-17-600-2288		MEMBRAAN, REMCILINDER	1			+	+	fig 1203-6
7	2590-17-600-2338		ONTLUCHTER	1			+	+	fig 1203-26
8	5310-17-600-2321		OPVULPLAAT, St, 1/32 in dik, remkamer, luchtdrukrem/steun	nb	1/2		+	+	fig 1203-17
9	5330-17-600-2319		PAKKINGRING, VILT, 1.1/4 x 2.1/2 x 7/16 in, remkamer, luchtdrukrem/steun	1	1/2		+	+	fig 1203-16
10	5315-17-002-2684		PEN, TAPS, St, 3 x 22 mm, gefosf, verstijvingsplaat, m/stang/drukstang	1			+	+	fig 1203-9
11	2530-17-706-9045		REMKAMER, LUCHTDUKREM, cpl, m/steun	1	1/2		+	+	
12	5306-17-015-9058		BOUT, ZESKANT, St, 3/8 in x 24 UNF-2A x 1.1/2 in, vcad	3			+	+	
13	5310-17-024-2958		MOER, ZESKANT, St, 3/8 in x 24 UNF-2B, vcad	3			+	+	
14	5310-17-003-7979		RING, VEER-, RECHT, St, B 10	3			+	+	
15	2530-17-007-2464		STEUN	1				+	fig 1203-18
16	4730-17-025-1727		STOP, PIJP, m/binnenzesk, St, 1/8 in NPT, vcad, huis	1			+	+	
17	4730-00-044-4691		STOP, PIJP, m/binnenzesk, St, 1/4 in NPT, vcad, dekse1	1			+	+	fig 1203-4
18	5340-17-600-2314		VEER, DRUK-, SCHROEFVORMIG, membraan	1				+	fig 1203-11
19	2530-17-007-2930		VERSTIJVINGSPLAAT, m/STANG, membraan					+	fig 1203-8

Volgnr	Artikelnummer		Artikelo omschrijving	aantal gemon- teerd	2e ech	3e ech	4e ech	Opmerkingen
	NATO Stocknummer	Fabrieksnummer						
	1	2						
			GROEP 12 - REMINSTALLATIE (vervolg)					
1	4730-17-015-2269		1208,10 - LUCHTFILTER, LUCHTLEIDINGEN en AANSLUITINGEN AANPASSTUK, RECHT, PIJP, m/zesk, cpl, mess, v/ 3/8 in pijp, 1/4 in NPT, uitw drd 4 - luchtfilter 2 - slangkoppelingnippel	6		+	+	
2	4730-17-015-2278		AANPASSTUK, RECHT, PIJP, m/zesk, cpl, mess, v/ 1/2 in pijp, 1/4 in NPT, uitw drd v/ remkamer, luchtdrukrem/lgd remkrachtregelaar v/reactieventiel/lgd remkrachtregelaar	2		+	+	fig 1203-1+2+3
3	4730-17-015-2268		AANPASSTUK, RECHT, PIJP, m/zesk, cpl, mess, v/ 1/2 in pijp, 1/2 in NPT, uitw drd, v/leiding remkrachtregelaar/remkamer, Tuchtdrukrem remkrachtregelaar/reactieventiel druktank/reactieventiel	3		+	+	
4	5340-17-017-4581		BEUGEL, INSTALLATIE, 2 x halfzadel, 1/2 maal 15 mm, leiding reactieventiel/druktank	1		+	+	
5	2530-00-426-8375		DEKSEL, LUCHTFILTER	2				fig 1204-6
6	5306-17-007-7400		BOUT, ZESKANT, St, 5/16 in x 18 UNC-2A x 1 in, vcad	8	+	+	+	fig 1204-4
7	5310-17-026-3972		RING, VEER-, RECHT, St, B 8	8	+	+	+	fig 1204-3
8	4730-17-015-5657		DICHTINGSRING, PIJP-SLANGFITTING, mess, 3/8 in, v/leiding slangkoppeling/luchtfilter, li en re luchtfilter/reactieventiel, li en re, 1 ^e , 2 ^e en 3 ^e deel	16		+	+	
9	4730-00-200-0437		DICHTINGSRING, PIJP-SLANGFITTING, mess, 1/2 in, v/leiding reactieventiel/druktank reactieventiel/remkamer, luchtdrukrem	8		+	+	fig 1203-2
10	4730-17-015-7510		DRUKRING, St, C15 (v/15 mm pijp), v/leiding druktank/lucht- filter, li en re	4		+	+	

Volgnr	Artikelnummer		Artikeleomschrijving	aantal gemon- teerd	2e ech	3e ech	4e ech	Opmerkingen
	NATO Stocknummer	Fabrieksnummer						
	1	2						
1	2530-00-350-6492		FILTER, PERS-, cpl, lucht	2	%	+	+	Afb 1204 r
2	5306-17-007-7407		BOUT, ZESKANT, St, 3/8 in x 16 UNC-2A x 1 in, vcad	4	+	+	+	
3	5310-17-003-7979		RING, VEER-, RECHT, St, B 10	4	+	+	+	
4	2530-00-523-8212		FILTERELEMENT, PERS-	2	+	+	+	fig 1204-1
5	4330-17-706-4318		HOUDER, filterelement	2				fig 1204-5
6	2530-17-601-3187		HUIS, LUCHT	2				fig 1204-8
7	5340-17-003-6733		KLEM, LUS, strop, St, 12 mm, vcad leiding filter/reactieventiel leiding slangkoppeling/luchtfILTER	15		+	+	
8	5340-17-003-6738		KLEM, LUS, strop, St, 16 mm, vcad leiding reactieventiel/remkrachtregelaar en druktank leiding remkrachtregelaar/remkamer, luchtdrukrem	21		+	+	
9	5306-17-007-7520		BOUT, ZESKANT, St, 1/4 in x 28 UNF-2A x 1/2 in, vcad	21		+	+	
10	5310-17-002-0309		RING, VEER-, RECHT, St, 1/4 in	21		+	+	
11	4730-17-026-3165		KLEMRING, PIJPFITTING, St, B15, (v/15 mm pijp), v/leiding druktank/afsluiter, veiligheid	4		+	+	
12	4730-17-003-7385		KLEM, SLANG, m/radiale schroef, St, 16-21 mm, vcad, slang, luchtleidingen reactieventiel/remkrachtregelaar	4		+	+	
13	4730-17-015-1966		KNIEPIJP, 90°, cpl, mess, v/ 3/8 in pijp, 1/4 in NPT, uitw drd (reactieventiel/l dg filter, re)	1		+	+	
14	4730-17-015-1963		KNIE, PIJP, 90°, cpl, mess, v/ 3/8 in pijp, 3/8 in NPT, uitw drd (reactieventiel/l dg filter, li)	1		+	+	
15	4730-17-015-1955		KNIE, PIJP, 90°, cpl, mess, v/ 1/2 in pijp, 3/8 in NPT, uitw drd koppelstuk, pijp/l dg reactieventiel reactieventiel/l dg druktank	2		+	+	

Volgnr	Artikelnummer		Artikelo omschrijving	aantal gemen- teerd	2e ech	3e ech	4e ech	Opmerkingen
	NATO Stocknummer	Fabrieksnummer						
	1	2						
			GROEP 12 - REMINSTALLATIE (vervolg) 1208.10 - LUCHTFILTER, LUCHTLEIDINGEN en AANSLUITINGEN (vervolg)					
1	4730-17-003-5956		KNIE, PIJP, m/zesk, 90 ⁰ , cpl, Gij, A15, v/15 mm pijp, M22 x 1.5 uitw drd, druktank/leiding afsluiter, veiligheid	2		+	+	
2	4730-17-003-5954		KOPPELSTUK, PIJP, mess, uitw drd, M22 x 1.5 en inw drd, 3/8 in NPT, druktank/knie, pijp	1		+	+	
3	4730-17-003-5953		KOPPELSTUK, PIJP, St, uitw drd, M22 x 1.5 en inw drd, 1/2 in NPT, vcad, remkrachtregelaar/leiding remkamer, luchtdrukrem	1		+	+	
4	4730-17-802-7751		NIPPEL, PIJP, m/zesk, cpl, mess, v/ 3/8 in pijp, leiding filter/reactieventiel, li en re	4		+	+	
5	4730-00-522-8623		NIPPEL, PIJP, m/zesk, zesk MOER en VEERRING, St, uitw drd, 1/2 in NPT en inw drd, 1/2 in NPT, lang 2.5/6 in slangkoppeling/chassis	2		+	+	
6	4730-17-003-7950		NIPPEL, PIJP, St, A15, M22 x 1.5, uitw drd, v/15 mm pijp, afsluiter, veiligheid	2		+	+	
7	4730-17-015-2261		NIPPELSAMENSTEL, PIJP, n/zesk, cpl, mess, v/2 maal 1/2 in pijp, tussen ldg, remkrachtregelaar/remkamer, luchtdrukrem	1		+	+	
8	5330-00-291-1975		PAKKING, FLENS, deksel, luchtfilter	2	+	+	+	fig 1204-2
9	5330-17-006-1595		PAKKINGRING, fiber, 12 x 19 x 1.5 mm, v/15 mm pijp	4	+	+	+	
10	5330-17-003-1590		PAKKINGRING, St, asbest, C22 x 27 (v/koppelstukken, pijp M22 x 1.5)	6	+	+	+	
11	4710-00-277-5527		PIJP, KOPER, naadloos, 3/8 in UD, wanddikte 0.035 in slangkoppeling/luchtfilter, li en re (L 2 x 700 mm) . luchtfilter/reactieventiel, li en re, 1e deel (L 2 x 700 mm) luchtfilter/reactieventiel, li en re, 2e deel (L 2 x 1780 mm)	nb		+	+	per foot

Detail 111,1st NSN 2330-17-022-0065

Volgnr	Artikelnummer		Artikelomschrijving	aantal gecom- pleerd	2e ech	3e ech	4e ech	Opmerkingen
	NATO Stocknummer	Fabrieksnummer						
	1	2						
1	5330-17-003-3852		PAKKINGRING, cu, 26.6 x 33.3 x 3 mm, koppelstuk, hoofdre- cilinder	1	+	+	+	fig 1203-46
2	5310-00-361-7052		PAKKINGRING, cu, 33/64 x 45/64 x 0.032 in 1 - pijpnippel, hoofdrencilinder 2 - stop, hoofdrencilinder 1 - remvloei-stoftank/nippel	4	+	+	+	fig 1203-41
3			RING, DUBBEL CONISCH, manchet hoofdrencilinder (H0001//132681)	1				fig 1203-33
4	2530-17-015-5157		RING, SLUIT-, St, zuiger, hoofdrencilinder	1		+	+	fig 1203-30
5	2910-17-015-9891		TANK, m/VULDOP en KETTING	1		+	+	fig 1203-52+53
6	5310-17-015-8581		MOER, ZESKANT, laag, St, 1/2 in x 20 UNF - 2B, vcad	1		+	+	fig 1203-51
7	5310-17-029-0275		RING, SLUIT-, St, 13.5 x 24 x 3 mm, vcad	1		+	+	fig 1203-49
8	5340-17-611-5630		VEER, DRUK-, SCHROEFVORMIG, zuiger (bi), hoofdrencilinder	1		+	+	fig 1203-35
9	5340-17-611-5628		VEER, DRUK-, SCHROEFVORMIG, zuiger (bu), hoofdrencilinder	1		+	+	fig 1203-34
10	5340-17-015-5146		VEERKLEM, BORG-, opsluitring, hoofdrencilinder	1		+	+	fig 1203-29
			1204.20 - WIELRENCILINDERS					
11	2530-17-015-0343		AFSTANDSTUK, St, zuiger/gaffel, expansiehuis	2			+	fig 1202-43
12	2530-17-611-5592		BESCHERMHOES, STOF EN VOCHT, ru, wielrencilinder (komt ook voor in onderdelenuitrusting 2530-17-027-8002)	2	+	+	+	fig 1202-56
13	5340-17-015-0310		BORGRING, uitw, St, type "SEEGER", hefboomsarm, afstand- bediening	4			+	fig 1202-51
14	5305-17-611-5679		BOUT, STEL, St, moer, rond/rem-schoen (boven)	2			+	fig 1202-9
15	5305-17-611-5663		BOUT, STEL, St, moer, rond/rem-schoen (onder)	2			+	fig 1202-15
16	5306-17-611-5678		BOUT, ZESKANT, St, v/begrenzen moer, rond, remstel-huis	2			+	fig 1202-16

Volgnr	Artikelnummer		Artikelomschrijving	aantal samen- teerd	2e ech	3e ech	4e ech	Opmerkingen
	NATO Stocknummer	Fabrieksnummer						
	1	2						
			GROEP 12 - REMINSTALLATIE (vervolg) 1204.20 - WIELREMCILINDERS (vervolg)					
1	2530-17-614-9327		BUS, AFSTAND, St, remstelhuis	2			+	fig 1202-13
2			CILINDER, HYDRAULISCHE REM, WIEL (H0001//39742)	2				fig 1202-54
3	2530-17-611-5564		CILINDERSAMENSTEL, HYDRAULISCHE REM, WIEL, cpl, m/hefboom, 1.1/2 in	2	9%	+	+	
4	5306-17-611-5681		BOUT, ZESKANT, St, 3/8 in x 16 NC - 2 x 3.1/8 in	8		+	+	fig 1202-52
5	2530-17-611-5595		PLAAT, BORG-, BOUT EN MOER, St	4		+	+	fig 1202-53
6	2530-17-015-0339		HEFBOOMSARM, AFSTANDBEDIENING, handrem	2			+	fig 1202-49
7	4730-17-024-2010		KLEM, SLANG, beschermhoes, wielremcilinders	2		+	+	
8	3120-17-022-3072		LAGER, GLIJ-, BUS, nylon, 10 x 12.7 x 10 mm, hefboomsarm, afstandbediening	2			+	
9			MANCHET, HYDRAULISCHE REMCILINDER, wielremcilinder (H0001//155058)	2				fig 1202-46
10	5310-17-611-5667		MOER, ROND, St, v/afstellen remschoen (boven)	2			+	fig 1202-10
11	5310-17-611-5662		MOER, ROND, St, v/afstellen remschoen (onder)	2			+	fig 1202-14
12	2530-17-027-8002		ONDERDELENUITRUSTING, CILINDERSAMENSTEL, HYDRAULISCHE REM, WIEL, m/hefboom	nb			+	+
13	2530-17-611-5592		<u>artikelomschrijving samengesteld artikel:</u> 1 - BESCHERMHOES, STOF EN VOCHT, ru				+	+
14			1 - MANCHET, HYDRAULISCHE REM (H0001//155058)					
15	5305-00-361-5112		ONTLUCHTINGSNIPPEL, HYDRAULISCHE REM, wielremcilinder	2		+	+	fig 1202-55
16	5315-17-611-5661		PEN, CILINDRISCH, St, hefboomsarm, afstandbediening	2			+	fig 1202-50
17			REMSTELHUIS, wielremcilinder (H0001//139758)	2				fig 1202-12

Volgnr	Artikelnummer		Artikeloomschrijving	aantal gemon- teerd	2e ech	3e ech	4e ech	Opmerkingen
	NATO Stocknummer	Fabrieksnummer						
	1	2						
1	4710-17-017-0143		PIJP, KOPER, 1/2 in UD, wanddikte 0.035 in reactieventiel/remkrachtregelaar (L 980 mm) reactieventiel/druktank (L 650 mm) remkrachtregelaar/luchtdrukrem (L 2130 mm)	nb		+	+	per foot
2	4710-17-026-1675		PIJP, STAAL, 15 mm UD, wanddikte 1.5 mm, in- en uitwendig verkoperd, leiding druktank/afsluiter, veiligheid (L 2 x 110 mm)	nb				per meter
3	4720-99-943-9437		SLANG, KUNSTSTOF, neopreen, 2 inlagen, 1/2 in ID leiding reactieventiel/remkrachtregelaar (L 60 mm) leiding remkrachtregelaar/remkamer, luchtdrukrem (L 60 mm)	nb		+	+	per foot
4	4730-17-600-2300		STOP, PIJP, zes kop, 1/4 in NPT, luchtfilter	2	+	+	+	fig 1204-7
5	5325-17-004-7246		TULE, RUBBER, 15 x 38 x 12 mm, leiding reactieventiel/lucht- filter	10		+	+	
6	8305-17-024-2033		VILTSTROOK, 15 x 2 mm, (L 630 mm), installatiebeugel	nb		+	+	per meter
7	4730-17-015-5659		WARTELMOER, PIJPKOPPELSTUK, zes kop, hoog, mess, v/ 3/8 in pijp, v/leiding slangkoppeling/luchtfilter, 11 en re luchtfilter/reactieventiel, li en re, 1e, 2e en 3e deel	16		+	+	
8	4730-00-054-2572		WARTELMOER, PIJPKOPPELSTUK, zes kop, hoog, mess, v/ 1/2 in pijp, v/leiding reactieventiel/druktank reactieventiel/remkrachtregelaar remkrachtregelaar/remkamer, luchtdrukrem	8		+	+	fig 1203-1
9	4730-17-004-7223		WARTELMOER, PIJPKOPPELSTUK, zes kop, St, AM 22 x 1.5 mm (v/15 mm pijp), v/leiding druktank/afsluiter, veiligheid	4		+	+	
			1208.20 - LUCHTKETELS					
10	4820-17-630-1748		AFSLUITER, AFTAP, M 22 x 1.5	2	+	+	+	
11	5340-17-001-7721		BAND, KLEM-, St, druktank	4	1/2	+	+	

Volgnr	Artikelnummer		Artikelomschrijving	aantal gemon- teerd	2e ech	3e ech	4e ech	Opmerkingen
	NATO Stocknummer	Fabrieksnummer						
	1	2						
			GROEP 12 - REMINSTALLATIE (vervolg)					
			1208.20 - LUCHTKETELS (vervolg)					
1	5310-17-024-2958		MOER, ZESKANT, St, 3/8 in x 24 UNF-2B, vcad	16	+	+	+	
2	5330-12-124-1037		PAKKINGRING, cu/asbest, C22 x 27 afdichtstop aftapstop	2	+	+	+	
3	5340-17-017-4611		STOP, CILINDRISCHR DRAAD, zesk kop, St, uitw drd, M22 x 1,5	1				
4	2530-17-001-9573		TANK, DRUK-, 20 liter	2	1	+	++	r
5	8305-17-024-2012		VILTSTROOK, 25 x 3 mm, (L 1400 mm), klemband, druktank	nb	+	+	+	per meter
			1208.50 - AFSLUITER, VEILIGHEID					
6	2530-17-027-3444		AFSLUITER, VEILIGHEID, cp1	1	1	+	+	fig 1205-1 r
7	5365-17-003-1873		BORGRING, inw, type "SEEGER", St, 20 x 1 mm, gefosf (ventiel)	1		+	+	fig 1205-7
8	5340-17-003-7273		BORGRING, uitw, type BZ, St, 3.2 mm (ringmoer) (alleen voor afsluiter, veiligheid, type 73R004)	1		+	+	
9	5306-17-022-0860		BOUT, STEL-, zesk kop en stompe kegelpunt, St, M8 x 35	1		+	+	fig 1205-2
10	5310-17-004-7783		MOER, ZESKANT, St, M8, vcad	1		+	+	fig 1205-3
11	2530-17-631-0560		HUIS, m/BUS, membraan (alleen te gebruiken voor afsluiter, veiligheid, type 73R00)	1			+	fig 1205-12
12	2530-17-007-2469		HUIS, m/BUS, membraan (alleen te gebruiken voor afsluiter, veiligheid, type 73R04)	1			+	
13	2530-17-631-0561		HUIS, zuigerdrukveer	1				fig 1205-4
14	5310-17-002-0309		RING, VEER-, RECHT, St, 1/4 in	4				fig 1205-6
15	5305-17-005-3597		SCHROEF, CILINDERKOP, St, AM 6 x 12, vcad	4				fig 1205-5
16	2530-17-630-1526		MEMBRAAN, ru	1			+	fig 1205-11

Volgnr	Artikelnummer		Artikelomschrijving	aantal geman- teerd	2e ech	3e ech	4e ech	Opmerkingen
	NATO Stocknummer	Fabrieksnummer						
	1	2						
		3	4	5	6	7	8	
1	5340-17-630-1686		RING, MET BUITENSCHROEFDRAAD, M22 x 1,5, ventiel drukveer (alleen te gebruiken voor afsluiter, veiligheid, type 73R00)	1			+	fig 1205-16
2	5340-17-630-1695		RING, MET BUITENSCHROEFDRAAD, M22 x 15, ventiel drukveer (alleen te gebruiken voor afsluiter, veiligheid, type 73R04)	1			+	
3	2530-17-631-0556		SCHOTEL, SCHROEFVORMIGE DRUKVEER, zuiger	1			+	fig 1205-7
4	2530-17-631-0554		VEER, DRUK-, SCHROEFVORMIG, ventiel	1			+	fig 1205-15
5	5340-17-630-1683		VEER, DRUK-, SCHROEFVORMIG, zuiger	1			+	fig 1208-8
6	2530-17-630-2639		VENTIEL, cp1 (alleen te gebruiken voor afsluiter, veiligheid, type 73R00)	1			+	fig 1205-14
7	2530-17-630-1528		VENTIEL, cp1 (alleen te gebruiken voor afsluiter, veiligheid, type 73R04)	1			+	
8	2530-17-631-0558		ZUIGER, St 1208.70 - REACTIE-VEILIGHEIDSVENTIEL en REM- KRACHTREGELAAR	1			+	fig 1205-9
9	2530-17-600-2290		AFSLUITER, TERUGSLAGKLEP, deksel, veiligheidsventiel	1				fig 1206-37
10	5340-00-672-0233		BORGRING, filterplaten, reactieventiel	1				fig 1206-2
11	2530-00-790-0992		DEKSEL, cp1, m/klepzitting, veiligheidsventiel (alleen voor reactieventiel, oude type)	1				fig 1206-57
12	5306-17-007-7400		BOUT, ZESKANT, St, 5/16 in x 18 UNC-2A x 1 in, vcad	2				fig 1206-45
13			BOUT, ZESKANT, St, 5/16 in x 18 UNC-2A x 1.1/2 in (H0001//182170)	2				fig 1206-45
14	5310-17-003-6149		RING, SLUIT-, St, 8,4 x 15 x 1,5 mm, vcad	4				fig 1206-46
15	2530-17-601-0445		DEKSEL, huis, reactieventiel	1				fig 1206-8
16	5306-17-007-7400		BOUT, ZESKANT, St, 5/16 in x 18 UNC-2A x 1 in, vcad	6				fig 1206-15
17	5310-17-003-6149		RING, SLUIT-, St, 8,4 x 15 x 1,5 mm, vcad	6				fig 1206-14

Volgnr	Artikelnummer		Artikeloomschrijving	aantal gemon- teerd	2e ech	3e ech	4e ech	Opmerkingen
	NATO Stocknummer	Fabrieksnummer						
	1	2						
			GROEP 12 - REMINSTALLATIE (vervolg)					
			1208.70 - REACTIE-VEILIGHEIDSVENTIEL en REMKRACHTREGELAAR (vervolg)					
1			DEKSEL, huis, veiligheidsventiel (H0001//339214)	1				
2	5306-17-007-7400		BOUT, ZESKANT, St, 5/16 in x 18 UNC-2A x 1 in, vcad	4				
3	5310-17-003-6149		RING, SLUIT-, St, 8.4 x 15 x 1.5 mm, vcad	4				
4	4730-17-600-2302		DRAADBUS, KOPPEL, m/zesk, in- en uitw drd, drukveer klepzit- ting/luchttoevoerleiding reactieventiel	1				fig 1206-4
5	4730-17-601-4570		DRAADBUS, KOPPEL, m/zesk, in- en uitw drd (alleen v/reactie- veiligheidsventiel, nieuwe type)	1				
6	4730-17-600-2312		DRAADBUS, KOPPEL, m/zesk, in- en uitw drd, inw drd 3/8 in NPT, deksel veiligheidsventiel (alleen v/reactie-veilig- heidsventiel, oude type)	1				fig 1206-41
7	2530-00-447-1145		DRUKREGELAAR, LUCHTDRUKREMSYSTEEM, cpl (alleen voor reactie- veiligheidsventiel, oude type)	1				fig 1206-51
8	2530-00-832-7579		<u>artikelomschrijving samengesteld artikel:</u>					
9	2530-00-447-1120		1 - KLEP					
10	5310-00-222-7161		1 - MEMBRAAN					
11	5310-17-800-7825		1 - MOER					
12	5310-17-800-7827		1 - VOLGPLAAT					
13	2530-00-339-5311		1 - VOLGPLAAT					
13	2530-00-339-5311		FILTER, deksel reactieventiel	1				fig 1206-20
14	2530-00-777-7528		FILTER, deksel veiligheidsventiel (alleen v/reactie-veilig- heidsventiel, nieuwe type)	1				
15	2530-00-422-8955		FILTER, (in stop) deksel veiligheidsventiel (alleen voor reactie-veiligheidsventiel, oude type)	1				fig 1206-39
16	2530-00-785-8025		FILTERELEMENT, PERS,- reactieventiel (alleen v/reactie-veilig- heidsventiel, nieuwe type)	1				

Volgnr	Artikelnummer		Artikeloomschrijving	aantal gemon- teerd	2e ech	3e ech	4e ech	Opmerkingen
	NATO Stocknummer	Fabrieksnummer						
	1	2						
1	2530-17-007-6565		FILTERPLAAT, reactieventiel	2				fig 1206-1
2	4730-17-007-6078		FLENS, PIJP, St, m/2 gaten 8.4 mm en 1/2 in x 14 NPS inw drd, v/aansluiten remkrachtregelaar	1		+	+	
3	2530-17-601-4576		GELEIDINGSAS, kegelventiel/membraan, veiligheidsventiel (al- leen v/reactie-veiligheidsventiel, oude type)	1				fig 1206-29
4			GELEIDINGSAS (alleen v/reactie-veiligheidsventiel, nieuwe type) (H0001//339218)	1				
5	3040-17-601-4576		GELEIDINGSAS, cpl, m/MOEREN, kegelventiel/membraan, veilig- heidsventiel (alleen v/ractie-veiligheidsventiel, nieuwe type)	1				
6	5330-17-630-1919		HOUDER, PAKKING, remkrachtregelaar	2			+	fig 1207-26
7	2530-00-970-0122		HOUDER, SCHROEFVORMIGE DRUKVEER, afsluiter, terugslagklep, veiligheidsventiel	1				fig 1206-36
8	2530-17-631-0713		HOUDER, SCHROEFVORMIGE DRUKVEER, remkrachtregelaar	1				fig 1207-21
9			HUIS (alleen v/reactie-veiligheidsventiel, nieuwe type) (H0001//304344)	1				
10	2530-17-023-5707		HUIS, boven, remkrachtregelaar	1				fig 1207-12
11	2530-17-023-5708		HUIS, onder, remkrachtregelaar	1				fig 1207-24
12	5306-17-003-6385		BOUT, ZESKANT, St, M8 x 30, vcad	4				
13	2530-17-601-0444		HUIS, reactieventiel	1				fig 1206-3
14	2530-00-832-7579		KLEP, drukregelaar, veiligheidsventiel (alleen v/reactie- veiligheidsventiel, oude type)	1				fig 1206-56
15	2530-00-785-8024		KLEP, reactieventiel (alleen v/reactie-veiligheidsventiel, nieuwe type)	1				
16	2530-00-970-0128		KLEP, reactieventiel (alleen v/reactie-veiligheidsventiel, oude type)	1				fig 1206-17
17	2530-17-630-2065		KLEP, cpl, remkrachtregelaar	1			+	fig 1207-11

Volgnr	Artikelnummer		Artikelo omschrijving	aantal gemon- teerd	2e ech	3e ech	4e ech	Opmerkingen
	NATO Stocknummer	Fabrieksnummer						
	1	2						
			GROEP 12 - REMINSTALLATIE (vervolg)					
			1208.70 - REACTIE-VEILIGHEIDSVENTIEL en REMKRACHTREGELAAR (vervolg)					
1			KLEPHUIS, veiligheidsventiel (alleen v/reactie-veiligheids- ventiel, oude type) (H0001//148328)	1				fig 1206-32
2	2530-17-601-4583		KLEPHUIS, cpl, veiligheidsventiel (alleen v/reactie-veilig- heidsventiel, nieuwe type)	1				
3	2530-17-007-2481		KLEPHUIS, cpl, veiligheidsventiel (alleen v/reactie-veilig- heidsventiel, oude type)	1				fig 1206-30
4	2530-17-007-2480		<u>artikelomschrijving samengesteld artikel:</u>					
5	5330-00-741-7359		1 - KLEPHUIS					
6	4820-17-007-6557		1 - PAKKINGRING, ru					
7	4820-17-007-6555		1 - ZITTING, KLEP, membraanklep					
8	2530-00-311-9233		1 - ZITTING, veiligheidsventiel					
9	2530-17-630-1921		KLEP, VEILIGHEIDSVENTIEL, kegelvormig	1				fig 1206-28
10			KRUK, HAND, remkrachtregelaar	1				fig 1207-28
11	2530-00-353-0485		MEMBRAAN, drukregelaar, in deksel, veiligheidsventiel (alleen v/reactie/veiligheidsventiel, oude type) (H0001//148357)	1				fig 1206-54
12	2530-00-032-2806		MEMBRAAN, reactieventiel	1				fig 1206-13
13	4820-17-007-6556		MEMBRAAN, veiligheidsventiel	1				fig 1206-60
14			MEMBRAANGELEIDER, membraan, reactieventiel (alleen v/reactie- veiligheidsventiel, oude type)	1				fig 1206-19
15	5310-17-017-2428		MEMBRAAN SCHOTEL (H0001//304336)	1				
16	5315-17-001-6765		MOER, KROON, zesks, kroon in het zesks, St, 1/4 in x 28 UNF-2B, vcad, geleidingsas, membraan, veiligheidsventiel (alleen v/reactie-veiligheidsventiel, oude type)	2				fig 1206-43
			PEN, SPLIT, St, 1.5 x 20 mm, gefosf	2				fig 1206-42

Volgnr	Artikelnummer		Artikelomschrijving	aantal gemon- teerd	2e ech	3e ech	4e ech	Opmerkingen
	NATO Stocknummer	Fabrieksnummer						
	1	2						
1			MOER, ZESKANT, St, klap/membraan, drukregelaar veiligheids-ventiel (alleen v/reactie-veiligheidsventiel, oude type) (H0001//148356)	1				fig 1206-52
2	5310-00-959-7600		MOER, ZESKANT, ZELFBORGEND, St, geleidingsas, membraan veiligheidsventiel (alleen v/reactie-veiligheidsventiel, nieuwe type)	2				
3	2530-17-630-2067		NOK, REGEL-, zuigerbediening, remkrachtregelaar	1			+	fig 1207-22
4	2530-17-630-1926		OPVULPLAAT, schroefvormige drukveer, zuiger (ond), remkrachtregelaar	1			+	fig 1207-18
5	2530-17-630-1927		OPVULPLAAT, schroefvormige drukveer, zuiger (ond), remkrachtregelaar	1			+	fig 1207-19
6	2530-17-630-1917		O-RING, 34.2 x 3 mm, zuiger, remkrachtregelaar	1			+	fig 1207-16
7	5330-00-291-4857		O-RING, ru, 3 mm dik, 19.2 mm ID, zuiger, remkrachtregelaar	1			+	fig 1207-7
8	5330-00-640-9612		O-RING, ru, 1/16 in dik, 3/16 in ID, membraan/geleidingsas (in huis veiligheidsventiel) (alleen v/reactie-veiligheidsventiel, oude type)	1				fig 1206-26
9	5330-17-600-2299		O-RING, ru, 1.016 in UD, stop, kegelventiel, veiligheidsventiel	1				fig 1206-61
10	5330-17-004-5461		PAKKING, FLENS, papier, flens remkrachtregelaar/chassisraam	1	%	+	+	fig 1207-3
11	1025-00-523-8166		PAKKING, PLAAT, SPECIAAL, reactie-veiligheidsventiel	1				fig 1206-22
12	2530-17-630-1920		PAKKINGRING, cilindrische pen, remkrachtregelaar	2			+	fig 1207-25
13	5330-17-002-0517		PAKKINGRING, fiber, A48 x 55 mm, stop remkrachtregelaar	1			+	fig 1207-6
14	5330-00-825-0578		PAKKINGRING, kegelvormige klap, veiligheidsventiel (alleen v/reactie-veiligheidsventiel, nieuwe type)	1				
15	5330-00-311-9188		PAKKINGRING, ru, 11/32 in UD, filter (in dekseel reactieventiel)	1				fig 1206-21
16	5330-00-741-7359		PAKKINGRING, ru, 1 in UD, zitting membraanklep, veiligheidsventiel	1				fig 1206-33

Volgnr	Artikelnummer		Artikeloomschrijving	aantal gemon- teerd	2e ech	3e ech	4e ech	Opmerkingen	
	NATO Stocknummer	Fabrieksnummer							
	1	2							
			GROEP 12 - REMINSTALLATIE (vervolg)						
			1208.70 - REACTIE-VEILIGHEIDSVENTIEL en REMKRACHTREGELAAR (vervolg)						
1	5330-00-804-6132		PAKKINGRING, ru, 1.05 in UD, stop, deksel, veiligheidsventiel (alleen v/reactie-veiligheidsventiel, nieuwe type)	1					
2	5330-00-311-9232		PAKKINGRING, ru, 1.109 in UD, klepzitting reactieventiel	1				fig 1206-5	
3	2530-00-741-7355		PAKKINGRING, ru, 1.156 in UD, stop, deksel, veiligheidsven- tief (alleen v/reactie-veiligheidsventief, oude type)	1				fig 1206-40	
4	5330-17-600-2306		PAKKINGRING, ru, 1.25 in UD, stop, drukveer klepzitting, reae- tiefventief	1				fig 1206-11	
5	5330-17-601-4571		PAKKINGRING, volgplaten, membraan, veiligheidsventief	2					
6	5315-17-631-0625		PEN, CILINDRISCH, remkrachtregelaar	1			+	fig 1207-27	
7			PEN, CILINDRISCH, MET HANDDRUK, remkrachtregelaar (H0001//145630)	1					
8	5315-17-001-6660		PEN, SPLIT, St, 3 x 20 mm, gefosf, cilindrische pen, rem- krachtregelaar	1			+	+	fig 1207-32
9	2520-17-630-1956		PLAAT, INSTRUCTIE, handkrukstand, remkrachtregelaar	1					fig 1207-13
10	2530-17-600-3930		REACTIE-VEILIGHEIDSVENTIEL, cp1 (nieuwe type)	1	%	+	+		
11	5306-17-001-7417		BOUT, ZESKANT, St, 3/8 in x 24 UNF-2A x 1.1/4 in, vcad	3	+	+	+		
12	5310-17-074-2958		MOER, ZESKANT, St, 3/8 in x 24 UNF-2B, vcad	3	+	+	+		
13	5310-17-003-7979		RING, VEER, RECHT, St, B10	3	+	+	+		
14	2530-00-611-9871		REACTIEVENTIEL, cp1 (alleen v/reactie-veiligheids- ventief, nieuwe type)	1					
15	2530-00-339-5295		REACTIEVENTIEL, cp1 (alleen v/reactie-veiligheidsventief, oude type)	1					
16	2530-17-630-8331		REMKRACHTREGELAAR, cp1 (Westinghouse 13 Bdr/W)	1	%	+	+		

Volgnr	Artikelnummer		Artikelomschrijving	aantal geman- teerd	2e ech	3e ech	4e ech	Opmerkingen
	NATO Stocknummer	Fabrieksnummer						
	1	2						
1	5306-17-015-9041		BOUT, ZESKANT, St, 5/16 in x 24 UNF-2A x 1.3/4 in, vcad	2	+	+	+	fig 1207-4
2	5310-17-017-9937		MOER, ZESKANT, St, 5/16 in x 24 UNF-2B, vcad	2	+	+	+	fig 1207-1
3	5310-17-026-3972		RING, VEER-, RECHT, St, B8	2	+	+	+	fig 1207-2
4	2530-00-426-8395		RING, MEMBRAAN, reactieventiel	1				fig 1206-12
5	5310-17-600-2313		RING, SLUIT-, membraan, drukregelaar, veiligheidsventiel (alleen v/reactie-veiligheidsventiel, oude type)	1				fig 1206-47
6	2530-00-426-8220		RING, SLUIT-, St, 0.010 in dik, v/klepveer, drukregelaar, veiligheidsventiel (v/70-80 lbs/in ² spanning) (alleen v/reactie-veiligheidsventiel, oude type)	nb				fig 1206-49
7	5310-17-600-2311		RING, SLUIT-, St, spec, kegelventiel/klepsteel, veiligheidsventiel	1				fig 1206-27
8	5310-17-601-4579		RING, VEER-, CONISCH, membraangeleider, membraan, reactieventiel (alleen v/reactie-veiligheidsventiel, nieuwe type)	1				
9	2530-00-426-8394		VEERRING, TAND, VERZONKEN, membraangeleider, membraan, reactieventiel (alleen v/reactie-veiligheidsventiel, oude type)	1				fig 1206-16
10	2530-17-007-6563		SCHOTEL, SCHROEFVORMIGE DRUKVEER, klepveer, reactieventiel (alleen v/reactie-veiligheidsventiel, oude type)	1				fig 1206-9
11	2530-17-630-1928		SCHOTEL, SCHROEFVORMIGE DRUKVEER, zuiger (ond), remkrachtregelaar	1			+	fig 1207-20
12	5315-17-004-7733		STIFT, KERF-, cil, St, 5 x 36 mm, cilindrische pen/regelnok, remkrachtregelaar	1		+	+	fig 1207-30
13	5315-17-003-7952		STIFT, KERF-, taps, St, 4 x 20 mm, cilindrische pen/handkruk, remkrachtregelaar	1		+	+	fig 1207-29
14	2530-17-630-2069		STOP, CILINDRISCHE DRAAD, remkrachtregelaar	1				fig 1207-5
15	2530-00-426-8221		STOP, CILINDRISCHE DRAAD, zesk kop, drukregelaar, veiligheidsventiel (alleen v/reactie-veiligheidsventiel, oude type)	1				fig 1206-48
16	5365-00-796-0948		STOP, CILINDRISCHE DRAAD, zesk, uitw drd, kegelventiel, veiligheidsventiel	1				fig 1206-25

- 04 - (1e verv)

W 6

Volgnr	Artikelnummer		Artikelomschrijving	aantal gemon- teerd	2e ech	3e ech	4e ech	Opmerkingen
	NATO Stocknummer	Fabrieksnummer						
	1	2						
			GROEP 12 - REMINSTALLATIE (vervolg)					
			1208.70 - REACTIE-VEILIGHEIDSVENTIEL en REMKRACHTREGELAAR (vervolg)					
1	4730-17-600-2298		STOP, PIJP, m/binnenzesk, 3/8 in, huis, reactieventiel	1				fig 1206-7
2	2530-17-630-1922		VEER, BLAD, v/vergrendelen handkrukstand, remkrachtregelaar	5			+	fig 1207-33
3	2530-00-766-4246		VEER, DRUK-, SCHROEFVORMIG, afsluiter, terugslagklep, veiligheidsventiel (alleen v/reactie-veiligheidsventiel, nieuwe type)	1				
4	2530-00-256-7203		VEER, DRUK-, SCHROEFVORMIG, drukregelaar, veiligheidsventiel (alleen v/reactie-veiligheidsventiel, oude type)	1				fig 1206-50
5	2530-00-339-5284		VEER, DRUK-, SCHROEFVORMIG, klep, reactieventiel	1				fig 1206-6
6	2530-00-339-5309		VEER, DRUK-, SCHROEFVORMIG, klepzitting, reactieventiel	1				fig 1206-8
7	5340-17-600-2296		VEER, DRUK-, SCHROEFVORMIG, membraan, veiligheidsventiel	1				fig 1206-38
8	2530-17-630-1923		VEER, DRUK-, SCHROEFVORMIG, ventiel, remkrachtregelaar	1			+	fig 1207-10
9	2530-17-630-1929		VEER, DRUK-, SCHROEFVORMIG, zuiger, remkrachtregelaar	1			+	fig 1207-8
10	2530-17-630-1918		VEER, DRUK-, SCHROEFVORMIG, zuiger (bo), remkrachtregelaar	1			+	fig 1207-14
11	2530-17-630-1924		VEER, DRUK-, SCHROEFVORMIG, zuiger (ond), remkrachtregelaar	1			+	fig 1207-17
12	2530-00-765-9445		VEILIGHEIDSVENTIEL, cp1 (alleen v/reactie-veiligheidsventiel, nieuwe type)	1				r
13	2530-17-007-2553		VEILIGHEIDSVENTIEL, cp1 (alleen v/reactie-veiligheidsventiel, oude type)	1				r
14	5306-17-007-7402		BOUT, ZESKANT, St, 5/16 x 18 UNC-2A x 2 in, vcad (alleen v/reactie-veiligheidsventiel, nieuwe type)	4				
15	5306-17-600-2309		BOUT, ZESKANT, St, spec, L 2.1/8 in (alleen v/reactie-veiligheidsventiel, oude type)	4				fig 1206-24
16	5310-17-003-6149		RING, SLUIT-, St, 8.4 x 15 x 1.5 mm, vcad	4				fig 1206-23

Detaillijst NSN 2330-17-022-0065

Volgnr	Artikelnummer		Artikelomschrijving	aantal gemon- teerd	2e ech	3e ech	4e ech	Opmerkingen
	NATO Stocknummer	Fabrieksnummer						
	1	2						
1	2530-17-630-2064		VENTILATIEPLAAT, onderhuis, remkrachtregelaar	1				fig 1207-31
2	5310-17-800-7827		VOLGPLAAT, membraan, drukregelaar, veiligheidsventiel (bo) (alleen v/reactie-veiligheidsventiel, oude type)	1				fig 1206-55
3	5310-17-800-7825		VOLGPLAAT, membraan, drukregelaar, veiligheidsventiel (ond) (alleen v/reactie-veiligheidsventiel, oude type)	1				fig 1206-53
4	4820-17-601-4586		VOLGPLAAT, membraan, veiligheidsventiel (bo) (alleen v/reactie-veiligheidsventiel, nieuwe type)	1				
5	2530-17-007-6558		VOLGPLAAT, membraan, veiligheidsventiel (bo) (alleen v/reactie-veiligheidsventiel, oude type)	1				fig 1206-35
6	2530-17-601-4575		VOLGPLAAT, membraan, veiligheidsventiel (ond) (alleen v/reactie-veiligheidsventiel, nieuwe type)	1				
7	4820-17-007-6560		VOLGPLAAT, membraan, veiligheidsventiel (ond) (alleen v/reactie-veiligheidsventiel, oude type)	1				fig 1206-44
8	4820-17-007-6555		ZITTING, KLEP, kegelventiel, veiligheidsventiel	1				fig 1206-31
9	2530-00-446-1287		ZITTING, KLEP, membraanklep, veiligheidsventiel (alleen v/reactie-veiligheidsventiel, nieuwe type)	1				
10	2530-00-970-0126		ZITTING, KLEP, membraanklep, veiligheidsventiel (alleen v/reactie-veiligheidsventiel, oude type)	1				fig 1206-34
11	2530-00-809-8872		ZITTING, KLEP, reactieventiel (alleen v/reactie-veiligheidsventiel, nieuwe type)	1				
12	4820-17-007-6564		ZITTING, KLEP, reactieventiel (alleen v/reactie-veiligheidsventiel, oude type)					fig 1206-10
13	2530-17-630-2068		ZUIGER, cpl, ventiel, remkrachtregelaar	1			+	fig 1207-9
14	2530-17-630-2066		ZUIGER, St, remkrachtregelaar	1			+	fig 1207-15
			1211.00 - SLANGKOPPELING					
15	2530-00-270-3878		BLINDE KOPPELING, REMLUCHTSLANG, VOERTUIG, m/handgreep en ketting, koppelingheft	2	+	+	+	

- 41 -
(1e verv)

W 6

Detaillijst NSN 2330-17-022-0065

Volgnr	Artikelnummer		Artikelomschrijving	aantal gemon- teerd	2e ech	3e ech	4e ech	Opmerkingen
	NATO Stocknummer	Fabrieksnummer						
	1	2						
			GROEP 12 - REMINSTALLATIE (vervolg) 1211.00 - SLANGKOPPELING (vervolg)					
1	5310-17-017-9933		MOER, ZESKANT, St, 1/4 in x 28 UNF-2B, vcad	2	+	+	+	
2	5310-17-002-0309		RING, VEER-, RECHT, St, 1/4 in	2	+	+	+	
3	4730-17-600-3910		KOPPELINGHELFT, SNEL-ONTKOPPELEND, cp1, 1/2 in NPT	2		+	+	
4	2530-00-090-2128		PAKKINGRING, ru, koppelinghelft	2	+	+	+	
5	2530-00-447-1107		PLUNJER, KLINK-, koppelinghelft	2		+	+	
6	5365-00-447-1106		STOP, CILINDRISCHE DRAAD, schroefvormige drukveer, koppelinghelft	2		+	+	
7	5340-00-597-0305		VEER, DRUK-, SCHROEFVORMIG, plunjer koppelinghelft	2		+	+	
			GROEP 13 - NAVEN, REMTROMMELS en WIELEN 1311.00 - NAVEN, REMTROMMELS en WIELEN					
8	5310-17-600-4480		BORGPLAAT, St, moer, naaflager	2	+	+	+	fig 1301-17
9	2530-17-006-2294		BORGRING, WIEL, LUCHTBAND	4	+	+	+	
10	2530-17-007-2479		DEKSEL, INSPECTIEGAT, wielnaaf	2	+	+	+	fig 1301-20
11	5306-17-007-7417		BOUW, ZESKANT, St, 1/2 in x 13 UNC-2A x 1.1/4 in, vcad	16	+	+	+	
12	5310-17-026-2306		RING, VEER-, GETAND, uitw, St, A 13.2, gezwart	16	+	+	+	
13	2530-17-006-2293		DRUKRING, WIEL, LUCHTBAND	4	+	+	+	
14	3110-00-100-0380		HUISRING, LAGER, bu, kegelager, 4.4375 in UD, 0.9375 in breed (wielnaaf, bu)	2	+	+	+	fig 1301-14
15	3110-00-100-0329		HUISRING, LAGER, bu, kegelager, 5.5115 in UD, 1.1250 in breed (wielnaaf, bi)	2	+	+	+	fig 1301-6
16	5330-17-630-1660		KEERRING, BEMANTELD, 100 x 141.6 x 26.2 mm, kegelager, wielnaaf, bi	2	+	+	+	fig 1301-4

- 42 -
(1e verv.)

W 6

Detaillijst MSN 2330-17-022-0065

Volgnr	Artikelnummer		Artikelomschrijving	aantal gemon- teerd	2e ech	3e ech	4e ech	Opmerkingen
	NATO Stocknummer	Fabrieksnummer						
	1	2						
1	3110-00-100-3095		LAGER, KEGEL, RADAXIAAL, ASRING, ER, 2.6250 in ID, 1.1830 in breed (wielnaaf, bu)	2	+	+	+	fig 1301-15
2	3110-17-605-8397		LAGER, KEGEL, RADAXIAAL, ASRING, ER, 3.000 in ID, 1.4212 in breed (wielnaaf, bi)	2	+	+	+	fig 1301-5
3	5310-17-600-4481		MOER, ZESKANT, laag, St, v/borgen moer, naaflager	4	+	+	+	fig 1301-16+18
4	5310-17-022-1803		MOER, ZESKANT, St, M 20 x 1.5, vcad (wielmoer)	16	+	+	+	fig 1301-13
5	5310-17-015-9586		RING, VEER-, CONISCH, St, C 20.5, vcad	16	+	+	+	fig 1301-12
6	2530-17-022-4661		NAAF	2	+	+	+	fig 1301-10 r
7	5330-17-017-4599		PAKKING, FLENS, 114 x 160 x 0.3 mm, wielnaafdeksel	2	+	+	+	fig 1301-19
8	2530-17-017-7964		REMTROMMEL	2	+	+	+	fig 1301-11 r
9	5307-17-022-1415		TAPEIND, BORST, St, M 20 x 1.5, vcad (wielbout)	16	+	+	+	fig 1301-9
10	5310-17-022-1855		MOER, ZESKANT, St, M 20 x 1.5, vcad	16	+	+	+	fig 1301-7
11	5340-17-023-1503		PLAAT, BORG-, BOUT EN MOER	8	+	+	+	fig 1301-8
12	2530-17-017-6848		WIEL, LUCHTBAND, m/borgring en drukring, B 6.50 x 20, bol- ting 142 mm	4	+	+	+	r
			1313.00 - BANDEN					
13	2610-17-002-9823		BAND, LUCHT, BINNEN, 9.00 - 20, m/ventielvoet	4	+	+	+	r
14	2610-17-029-4404		BAND, LUCHT, BUITEN, 12 koordlagen, wegprofiel, 9.00 - 20	4	+	+	+	r
15	2640-17-701-7141		BINNENVENTIEL, LUCHTBAND	4	+	+	+	
16	2640-17-701-7173		DOP, STOF, LUCHTBANDVENTIEL	4	+	+	+	
17	5330-17-003-8181		PAKKINGRING, ru, 8 x 25 x 3 mm, ventiel	4	+	+	+	
18	2640-17-022-5329		VELGLINT, ru, E 20	4	+	+	+	
19	2640-17-003-7617		VENTIEL, LUCHTBAND, bu, cp1, opdraaibaar, 2 maal gebogen	4	+	+	+	

Volgnr	Artikelnummer		Artikelomschrijving	aantal gemon- teerd	2e ech	3e ech	4e ech	Opmerkingen
	NATO Stocknummer	Fabrieksnummer						
	1	2						
			GROEP 15 - CHASSIS 1501.00 - CHASSISRAAM					
1			AFDEKKING, gat richtinglampstekerdoos (H0711//4051)	1				
2	5310-17-015-7108		MOER, ZESKANT, St, M 5 x 0,8, vcad	3	+	+	+	
3	5310-17-003-7983		RING, VEER-, RECHT, St, B5	3	+	+	+	
4	5305-17-003-5867		SCHROEF, CILINDERKOP, St, M5 x 18, vcad	3	+	+	+	
5			CHASSISRAAM, cp1 (H0001//144377)	1				
6			HOUDER, St, rong (H0001//147295)	24				
7	5306-17-001-7409		BOUT, ZESKANT, St, 1/2 in x 20-2A x 1 in, vcad	4	+	+	+	
8	5306-17-007-7556		BOUT, ZESKANT, St, 1/2 in x 20 UNF-2A x 1.1/4 in, vcad	88	+	+	+	
9	5310-17-029-0275		RING, SLUIT-, St, 13,5 x 24 x 3 mm, vcad	92	+	+	+	
10	5310-17-026-2306		RING, VEER-, GETAND, uitw, St, A 13,2, gezwart	92	+	+	+	
11	5315-17-024-4233		PEN, CILINDRISCH, St, scharnierblad, achterklep (alleen voor NSN 2330-17-022-0065)	4		+	+	
12	5306-17-007-7532		BOUT, ZESKANT, St, 5/16 x 24 UNF-2A x 1 in, vcad	8		+	+	
13	5310-17-017-9937		MOER, ZESKANT, St, 5/16 in x 24 UNF-2B, vcad	8		+	+	
14	5310-17-025-5663		RING, VEER-, GETAND, uitw, St, A8,4, gezwart	8		+	+	
			1504.00 - RESERVEWIELDRAGER					
15	2590-17-007-6075		KLEMSCHIJF, St	1	+	+	+	
16	5305-17-004-7740		SCHROEF, VLEUGEL	1	+	+	+	
17	5315-17-001-6676		PEN, SPLIT, St, 4 x 40 mm, gefosf	2	+	+	+	

Volgnr	Artikelnummer		Artikelomschrijving	aantal gemeen- teerd	2e ech	3e ech	4e ech	Opmerkingen
	NATO Stocknummer	Fabrieksnummer						
	1	2						
			1506.00 - KOPPELPEN					
1	2510-17-003-4016		KOPPELPEN, OPLEGGERKOPPELING	1				
2	5320-17-003-3856		NAGEL, KLINK-, MASSIEF, verz kop, 75 ^o , St, 22 x 52 mm	6				
			1507.00 - PARKEERSTEUN					
3	4730-17-007-1812		NIPPEL, SMEER-, hydr, recht, 1/8 in NPT lager, slingeras brug, steunwielen	6	+	+	+	fig 1501-12
4	5330-17-026-0514		O-RING, ru, 5.34 mm dik, 91.44 mm ID (geleiblok)	2		+	+	fig 1501-38
5	9320-17-706-8743		RUBBERBAND, MASSIEF, 25 x 3 mm, dekseel, tandwielhuis	nb	+	+	+	fig 1501-32 per meter
			GROEP 16 - VERING en SCHOKB REKERS					
			1601.10 - VERING					
6	5306-17-022-5031		BOUT, KAASKOP, St, 1/2 in x 20 UNF-2A x 210 mm (torenbout)	2	+	+	+	
7	5310-17-017-9932		MOER, ZESKANT, St, 1/2 in x 20 UNF-2B, vcad	2	+	+	+	
8	5306-17-024-3419		BOUT, KRAAG, St, 1 in x 14 UNF-2A, vcad (veerbout)	2	+	+	+	
9	5310-17-022-2325		MOER, ZESKANT, ZELFBORGEND, St, 1 in x 14 UNF-3B, vcad	2	+	+	+	
10	5310-17-003-8211		RING, SLUIT-, 27 x 50 x 5 mm, vcad	2	+	+	+	
11	5365-17-022-2140		BUS, AFSTAND, St, 13 x 11 x 82 mm, kleem veerpakket	4			+	
12	5306-17-007-7550		BOUT, ZESKANT, St, 3/8 in x 24 UNF-2A x 4.1/2 in, vcad	4			+	
13	5310-17-024-2958		MOER, ZESKANT, St, 3/8 in x 24 UNF-2B, vcad	4			+	
14	5310-17-003-7979		RING, VEER-, RECHT, St, 810, gezwart	4			+	
15	5365-17-017-5995		BUS, RUBBER, aanslag	2	+	+	+	
16	5306-17-001-6858		BOUT, ZESKANT, St, 1/2 in x 20 UNF-2 x 4.5/8 in, vcad	2	+	+	+	

45 - (1e verv)

W 6

Detaillijst NSN 2330-17-022-0065

- 46 -
(1e versie)

W 6

Volgnr	Artikelnummer		Artikelomschrijving	aantal gemeen- teerd	2e ech	3e ech	4e ech	Opmerkingen
	NATO Stocknummer	Fabrieksnummer						
	1	2						
			GROEP 16 - VERING en SCHOKBREKERS (vervolg)					
			1601.10 - VERING (vervolg)					
1	5310-17-017-9932		MOER, ZESKANT, St, 1/2 in x 20 UNF-2B, vcad	2	+	+	+	
2	5310-00-010-3323		RING, VEER-, RECHT, St, 1/2 in, vcad	2	+	+	+	
3	5365-17-022-6562		BUS, RUBBER, kraagbout	4	+	+	+	
4	2510-17-017-7492		KLEM, VEERPAKKET, VOERTUIG	4			+	
5	5320-17-005-9540		NAGEL, KLINK-, MASSIEF, balkop, St, 8 x 22 mm	4			+	
6	2510-17-017-7491		KLEM, VEERPAKKET, VOERTUIG (hulpvering)	4			+	
7	5320-17-005-9540		NAGEL, KLINK-, MASSIEF, St, 8 x 22 mm	4			+	
8	5340-17-024-0713		STOOTDOP, RUBBER, veeraanslag	2	+	+	+	
9	5306-17-007-7532		BOUT, ZESKANT, St, 5/16 in x 24 UNF-2A x 1 in, vcad	4	+	+	+	
10	5310-17-026-3972		RING, VEER-, RECHT, St, B8, gezwart	4	+	+	+	
11	5306-17-003-3860		U-BOUT	4	+	+	+	
12	5310-00-285-7084		MOER, ZESKANT, ZELFBORGEND, St, 3/4 in x 16 UNF-3B	8	+	+	+	
13	2510-17-017-2473		VEER, BLAD, hoofdblad, nr 1	2			+	
14	2510-17-017-2471		VEER, BLAD, hoofdblad, nr 2	2			+	
15	2510-17-017-2481		VEER, BLAD, hoofdblad (hulpvering)	2			+	
16	2510-17-017-2469		VEER, BLAD, volgblad, nr 1	2			+	
17	5340-17-025-0145		VEER, BLAD, volgblad, nr 2	2			+	
18	5340-17-025-0146		VEER, BLAD, volgblad, nr 1 (hulpvering)	2			+	
19	2510-17-007-9342		VEER, BLAD, volgblad, nr 2 (hulpvering)	2			+	
20	2510-17-007-9343		VEER, BLAD (te gebruiken als tussenblad, achterveer/hulpveer)	2			+	
21	2510-17-003-2398		VEERPAKKET, VOERTUIG (hulpvering)	2	+	+	+	

Detail 111 Jet MSN 2330-17-022-0065

r

Volgnr	Artikelnummer		Artikeloomschrijving	aantal gemon- teerd	2e ech	3e ech	4e ech	Opmerkingen
	NATO Stocknummer	Fabrieksnummer						
	1	2						
1	2510-17-024-0597		VEERPAKKET, VOERTUIG, z/bussen en torenbout	2	+	+	+	r
2	2510-17-007-2602		VEERPLAAT, bo	2		+	+	
3	2510-17-023-1425		VEERPLAAT, ond	2		+	+	
			1604.00 - SCHOKDEMPE					
4	5340-17-003-9589		BUS, RUBBER	8	+	+	+	
5	2540-17-003-7212		SCHOKDEMPE, DIRECTWERKEND, m/bussen (330/502, oogtype G)	2	+	+	+	r
6	5310-00-050-3331		MOER, ZESKANT, ZELFBORGEND, St, 5/8 in x 18 UNF-2B, vcad	4	+	+	+	
7	5310-17-003-7284		RING, SLUIT-, St, 17 x 50 x 4 mm, vcad	4	+	+	+	
8	5310-17-003-7998		RING, SLUIT-, St, 26 x 50 x 4 mm	2	+	+	+	
9	2510-17-023-1437		STEUN, VOOR	2				
10	5306-17-001-7417		BOUT, ZESKANT, St, 3/8 in x 24 UNF-2A x 1.1/4 in, vcad	8				
11	5310-17-024-2958		MOER, ZESKANT, St, 3/8 in x 24 UNF-2B, vcad	8				
12	5310-17-003-7979		RING, VEER-, RECHT, St, B10	8				
			GROEP 18 - LAADBAK					
			1808.00 - OPBERGMIDDELEN, v/VOERTUIGUITRUSTING					
13	5140-17-007-4669		GEREEDSCHAPSKIST, cp1	1				
14	5306-17-015-9058		BOUT, ZESKANT, St, 3/8 in x 24 UNF-2A x 1.1/2 in, vcad	2				
15	5306-17-017-4239		BOUT, ZESKANT, St, 3/8 in x 24 UNF-2A x 3/4 in, vcad	6				
16	5310-17-024-2958		MOER, ZESKANT, St, 3/8 in x 24 UNF-2B, vcad	8				
17	5310-17-003-1142		RING, SLUIT-, St, 10.5 x 21 x 2.5 mm, vcad	2				
18	5310-17-003-7979		RING, VEER-, RECHT, St, B10	8				
19	5340-17-006-8723		HANDGREEP, kast, zeilopberging (<u>alleen voor</u> NSN 2330-17-022-0066)	2				

Volgnr	Artikelnummer		Artikelomschrijving	aantal gemon- teerd	2e ech	3e ech	4e ech	Opmerkingen
	NATO Stocknummer	Fabrieksnummer						
	1	2						
			GROEP 18 - LAADBAK (vervolg)					
			1808.00 - OPBERGMIDDELEN, v/VOERTUIGUITRUSTING (vervolg)					
1	5306-17-006-7107		BOUW, ZESKANT, St, 1/4 in x 28 UNF-2A x 5/8 in, vcad	8				
2	5310-17-017-9933		MOER, ZESKANT, St, 1/4 in x 28 UNF-2B, vcad	8				
3	5310-17-002-0309		RING, VEER-, RECHT, St, 1/4 in, gezwart	8				
4	5340-17-025-4724		HANDGREEP, VAST, riem, kast, zeilopbergang (<u>alleen voor NSN 2330-17-022-0066</u>)	4		+	+	
5	5306-17-004-6376		BOUW, KLEM-, bolkop, St, 1/4 in x 20 UNC-2A x 1.1/2 in, vcad	8		+	+	
6	5310-17-002-6270		MOER, ZESKANT, St, 1/4 in x 20 UNC-2B, vcad	8		+	+	
7	2520-17-023-5219		KAST, St, v/opbergen accu en gelijkrichter (<u>alleen voor NSN 2330-17-022-0056</u>)	1				
8	5306-17-004-6376		BOUW, KLEM-, bolkop, St, 1/4 in x 20 UNC-2A x 1.1/2 in, vcad	4				
9	5306-17-017-4239		BOUW, ZESKANT, St, 3/8 in x 24 UNF-2A x 3/4 in, vcad	8				
10	5310-17-002-6270		MOER, ZESKANT, St, 1/4 in x 20 UNC-2B, vcad	4				
11	5310-17-024-2958		MOER, ZESKANT, St, 3/8 in x 24 UNF-2B, vcad	8				
12	5310-17-003-7979		RING, VEER-, RECHT, St, B10	8				
13			KAST, OPSLAG, St, v/opbergen zeil (<u>alleen voor NSN 2330-17-022-0066</u>) (H0001/151043)	1				
14	5306-17-007-7541		BOUW, ZESKANT, St, 3/8 in x 24 UNF-2A x 7/8 in, vcad	12				
15	5310-17-024-2958		MOER, ZESKANT, St, 3/8 in x 24 UNF-2B, vcad	12				
16	5310-17-003-7979		RING, VEER-, RECHT, St, B10	12				
17	5315-17-003-6749		PEN, CILINDRISCH, MET KOP, cp], m/ketting, en MUSKETON, kast zeilopbergang (<u>alleen voor NSN 2330-17-022-0066</u>)	2	+	+	+	

Volgnr	Artikelnummer		Artikelomschrijving	aantal gemon- teerd	2e ech	3e ech	4e ech	Opmerkingen
	NATO Stocknummer	Fabrieksnummer						
	1	2						
		3	4	5	6	7	8	
1	5340-17-003-4299		RIEM, WEBBING, canvas, m/GESP, kast zeilopberging (1.1/2 in breed, 1.50 m lang) <u>(alleen voor NSN 2330-17-022-0066)</u>	2	+	+	+	
2	5340-17-003-4298		RIEM, WEBBING, canvas, met TIP, kast, zeilopberging (1.1/2 in breed, 1.50 m lang) <u>(alleen voor NSN 2330-17-022-0066)</u>	2	+	+	+	
3	5340-17-004-6876		STOOTDOP, RUBBER, opbergkast, accu en gelijkrichter <u>(alleen voor NSN 2330-17-022-0065)</u>	3	+	+	+	
4	5306-17-007-7525		BOUT, ZESKANT, St, 1/4 x 28 UNF-2A x 1.1/4 in, vcad	3	+	+	+	
5	5310-17-015-8546		MOER, ZESKANT, laag, St, 1/4 in x 28 UNF-2B, vcad	3	+	+	+	
			1810.00 - LAADBAK <u>(alleen voor NSN 2330-17-022-0065)</u>					
6	2510-17-003-5942		ACHTERKLEP, VOERTUIGOPBOUW, cpl, m/GRENDELS	1	+	+	+	
7	5315-17-001-6685		PEN, SPLIT, St, 5 x 30 mm, gefosf	1	+	+	+	
8	5310-17-003-1138		RING, SLUIT-, St, 21 x 36 x 4 mm, gefosf	1	+	+	+	
9	2540-17-004-6865		DEURKRUK	1	+	+	+	
10	5315-17-001-6639		PEN, SPLIT, St, 2 x 20 mm, gefosf	1	+	+	+	
11	5310-17-003-1142		RING, SLUIT-, St, 10.5 x 21 x 2.5 mm, vcad	1	+	+	+	
12	5305-17-017-9378		SCHROEF, HOUT, PLATVERZONKEN, St, m6 x 1 in	2	+	+	+	
13	2510-17-015-2011		DEUR, METAAL, SCHARNIEREND, cpl, li	1	+	+	+	
14	2510-17-015-1956		DEUR, METAAL, SCHARNIEREND, cpl, re	1	+	+	+	
15	5306-17-007-7547		BOUT, ZESKANT, St, 3/8 in x 24 UNF-2A x 3 in, vcad	6	+	+	+	
16	5310-17-024-2958		MOER, ZESKANT, St, 3/8 in x 24 UNF-2B, vcad	6	+	+	+	
17	5310-17-003-7979		RING, VEER-, RECHT, St, B10	6	+	+	+	
18	5340-17-022-6157		DUIM, KLINK; li achterklep	1				
19	5340-17-022-6122		DUIM, KLINK; re achterklep	1				
20	5306-00-012-0231		BOUT, SLOT, bolkop, St, 5/16 in x 18 UNC-2A x 1.3/4 in	8				

Volgnr	Artikelnummer		Artikelomschrijving	aantal gemon- teerd	2e ech	3e ech	4e ech	Opmerkingen
	NATO Stocknummer	Fabrieksnummer						
	1	2						
			GROEP 18 - LAADBAK (vervolg)					
			1810.00 - LAADBAK (alleen voor NSN 2330-17-022-0065) (vervolg)					
1	5310-17-015-6340		MOER, ZESKANT, St, 5/16 in x 18 UNC-2B, vcad	8				
2	5340-17-003-4040		HAAK, DEUR, cp1	2	+	+	+	
3	5306-17-024-2931		BOUT, ZESKANT, St, 1/4 in x 20 UNC-2A x 1.1/2 in, vcad	6	+	+	+	
4	5310-17-002-6270		MOER, ZESKANT, St, 1/4 in x 20 UNC-2B, vcad	6	+	+	+	
5	5310-17-002-0309		RING, VEER-, RECHT, St, 1/4 in	6	+	+	+	
6	3120-17-004-6888		LAGER, GLIJ-, BUS, deurscharnier 4 - deur, li en re voor 6 - deur, li en re achter	10	+	+	+	
7	2510-17-007-2556		OPSTAPBEUGEL, aan achterklep	2	+	+	+	
8	5310-17-017-9937		MOER, ZESKANT, St, 5/16 in x 24 UNF-2B, vcad	8	+	+	+	
9	5305-17-017-9648		SCHROEF, PLATVERZONKEN, St, 5/16 in x 24 UNF-2A x 1.3/4 in, vcad	8	+	+	+	
10	5315-17-004-7747		PEN, CILINDRISCH, MET KOP, St, 6h11 x 18 x 15.5, vcad (deur- haak)	2	+	+	+	
11	5315-17-001-6765		PEN, SPLIT, St, 1.5 x 20 mm, gefosf	2	+	+	+	
12	5310-17-003-1135		RING, SLUIT-, St, 6.4 x 12 x 1.5 mm, vcad	2	+	+	+	
13	5340-17-006-8728		SCHARNIERBLAD, achterklep	4				
14	5306-17-004-6376		BOUT, SLOT, bolkop, St, 1/4 in x 20 UNC-2A x 1.1/2 in, vcad	40				
15	5310-17-002-6270		MOER, ZESKANT, St, 1/4 in x 20 UNC-2B, vcad	40				
16	5340-17-006-8726		SCHARNIERBLAD, deur, li en re	4				
17	5340-17-006-8727		SCHARNIERBLAD, deur, li en re	2				

Volgnr	Artikelnummer		Artikelomschrijving	aantal gemon- teerd	2e ech	3e ech	4e ech	Opmerkingen
	NATO Stocknummer	Fabrieksnummer						
	1	2						
1	5306-17-004-6376		BOUT, KLEM-, bolkop, St, 1/4 in x 20 UNC-2A x 1.1/2 in, vcad	72				
2	5310-17-002-6270		MOER, ZESKANT, St, 1/4 in x 20 UNC-2B, vcad	72				
3	5310-17-017-9937		MOER, ZESKANT, St, 5/16 in x 24 UNF-2B, vcad	12				
4	5305-17-017-9648		SCHROEF, PLATVERZONKEN, St, 5/16 in x 24 UNF-2A x 1.3/4 in, vcad	12				
5	5340-17-006-8729		SLOT, cpl, m/SLUITNOKKEN	1	+	+	+	
6	5305-00-267-8982		BOUT, ZESKANT, St, 1/4 in x 28 UNF-2A x 2.1/4 in, vcad	4	+	+	+	
7	5305-00-012-4064		BOUT, ZESKANT, St, 1/4 in x 28 UNF-2A x 2.1/2 in, vcad	4	+	+	+	
8	5310-17-015-8546		MOER, ZESKANT, laag, St, 1/4 in x 28 UNF-2B, vcad	8	+	+	+	
9	5310-17-002-0309		RING, VEER-, RECHT, St, 1/4 in	8	+	+	+	
10	5340-17-004-6876		STOOTDOP, RUBBER 2 - achterklep (aan chassis) 2 - deur, li en re	4	+	+	+	
11	5306-17-007-7525		BOUT, ZESKANT, St, 1/4 in x 28 UNF-2A x 1.1/4 in, vcad	2	+	+	+	
12	5310-17-015-8546		MOER, ZESKANT, laag, St, 1/4 in x 28 UNF-2B, vcad	2	+	+	+	
13	5305-17-003-5879		SCHROEF, CILINDERKOP, St, 5 x 30 mm, vcad	2	+	+	+	
14	5340-17-007-6290		VEER, BLAD, v/borgen, achterklepgrendel	2	+	+	+	
15	5306-17-004-6376		BOUT, KLEM-, bolkop, St, 1/4 in x 20 UNC-2 x 1.1/2 in, vcad	4	+	+	+	
16	5310-17-002-6270		MOER, ZESKANT, St, 1/4 in x 20 UNC-2B, vcad	4	+	+	+	
			1810.00 - LAADBAK (alleen voor NSN 2330-17-022-0066)					
17			ACHTERKLEP, VOERTUIGOPBOUW, cpl (H0001//158936)	1				

Volgnr	Artikelnummer		Artikelomschrijving	aantal gemen- teerd	2e ech	3e ech	4e ech	Opmerkingen
	NATO Stocknummer	Fabrieksnummer						
	1	2						
			GROEP 18 - LAADBAK (vervolg) 1810.00 - LAADBAK (alleen voor <u>NSN 2330-17-022-0066</u>) (vervolg)					
1	5306-17-003-2832		BOUT, DOG, St, 5/8 in x 11 UNC-2A, v/vastklemmen achterklep (aan hoekrong, li en re achter)	2	+	+	+	
2	5306-17-001-7415		BOUT, ZESKANT, St, 3/8 in x 24 UNF-2A x 2 in, vcad	2	+	+	+	
3	5310-17-003-7979		RING, VEER-, RECHT, St, B10	2	+	+	+	
4			DEUR, cpl, m/GRENDEL, li achter (H0001//148206) re achter (H0001//148205) li voor (H0001//148207) re voor (H0001//148208)	1				
5	5306-17-007-7547		BOUT, ZESKANT, St, 3/8 in x 24 UNF-2A x 3 in, vcad	10	+	+	+	
6	5310-17-024-2958		MOER, ZESKANT, St, 3/8 in x 24 UNF-2B, vcad	10	+	+	+	
7	5310-17-003-7979		RING, VEER-, RECHT, St, B10	10	+	+	+	
8			GRENDEL, cpl, achterklep (H0001//158941)	2	+	+	+	
9	5306-00-012-6385		BOUT, SLOT, bolkop, St, 5/16 in x 18 UNC-2A x 2.1/4 in, vcad	8	+	+	+	
10	5310-17-015-6340		MOER, ZESKANT, St, 5/16 in x 18 UNC-2B, vcad	8	+	+	+	
11	5340-17-003-4040		HAAK, DEUR, cpl	4	+	+	+	
12	5306-17-024-2931		BOUT, ZESKANT, St, 1/4 in x 20 UNC-2A x 1.1/2 in, vcad	12	+	+	+	
13	5310-17-002-6270		MOER, ZESKANT, St, 1/4 in x 20 UNC-2B, vcad	12	+	+	+	
14	5310-17-002-0309		RING, VEER-, RECHT, St, 1/4 in	12	+	+	+	
15			HAAK, trekkabel, slot, achterklep (H0001//181080)	4				
16	5310-17-015-8546		MOER, ZESKANT, laag, St, 1/4 in x 28 UNF-2B, vcad	4	+	+	+	
17	5310-17-015-5361		RING, SLUIT-, St, 6.4 mm x 25.4 x 1.6 mm, vcad	4	+	+	+	

Volgnr	Artikelnummer		Artikelomschrijving	aantal gemen- teerd	2e ech	3e ech	4e ech	Opmerkingen
	NATO Stocknummer	Fabrieksnummer						
	1	2						
1			HAAK, v/bevestigen staaldraadkabel aan liertrommel (H0001//181816)	1				
2	5306-17-022-0591		BOUT, ZESKANT, St, 5/16 in x 24 UNF-2A x 3/4 in, vcad	1	+	+	+	
3	5310-17-003-8217		RING, SLUIT-, St, 8,4 x 17 x 2 mm, vcad	1	+	+	+	
4	4010-17-025-8342		KABEL, STAALDRAAD, 4 mm, grendel, achterklep (L 1000 mm)	nb	+	+	+	per meter
5	4010-17-026-1241		KABEL, STAALDRAAD, type S/Z, 8 mm, gegalv (L 1500 mm) (lierkabel achterklep)	nb	+	+	+	per meter
6	4030-00-233-9567		KLEM, St, 3/16 in, gegalv staaldraadkabel (grendel achterklep)	2	+	+	+	
7			KOPPELBUS, lieras/slingerass (H0001//158955)	1				
8	5315-17-001-6698		PEN, SPLIT, St, 6 x 40 mm, gefosf	2	+	+	+	
9	3120-17-004-6888		LAGER, GLIJ-, BUS, deurscharnier	6		+	+	
10	3830-17-007-6294		LAGER, GLIJ-, BUS, slingerass lier, achterklep	1	+	+	+	
11	5306-17-007-7532		BOUT, ZESKANT, St, 5/16 in x 24 UNF-2A x 1 in, vcad	2	+	+	+	
12	5310-17-017-9937		MOER, ZESKANT, St, 5/16 in x 24 UNF-2B, vcad	2	+	+	+	
13	5310-17-025-5663		RING, VEER-, GETAND, uitw, St, A8.4	2	+	+	+	
14			LIER, achterklep (H0001//158562)	1				
15	5306-17-007-7557		BOUT, ZESKANT, St, 1/2 in x 20 UNF-2A x 1.1/2 in, vcad	4	+	+	+	
16	5310-17-017-9932		MOER, ZESKANT, St, 1/2 in x 20 UNF-2B, vcad	4	+	+	+	
17	5310-17-003-7984		RING, VEER-, RECHT, St, B14	4	+	+	+	
18			MOER, VLEUGEL, St, 5/8 in x 11 NC-2, oogbout (H0001//148247)	2				
19	5315-17-001-6675		PEN, SPLIT, St, 4 x 30 mm, gefosf	2	+	+	+	
20	5315-17-003-7872		PEN, CILINDRISCH, St, m/afgeknotte kegeloinden, 16h11 x 55 x 45, vcad (kabelschijf lierkabel, achterklep a /chassis)	2	+	+	+	
21	5315-17-001-6675		PEN, SPLIT, St, 4 x 30 mm, gefosf	4	+	+	+	

Volgnr	Artikelnummer		Artikelomschrijving	aantal gemon- teerd	2e ech	3e ech	4e ech	Opmerkingen
	NATO Stocknummer	Fabrieksnummer						
	1	2						
			GROEP 18 - LAADBAK (vervolg)					
			1810.00 - LAADBAK (alleen voor NSN 2330-17-022-00666)					
			(vervolg)					
1	5310-17-003-1133		RING, SLUIT-, St, 17 x 30 x 3 mm, vcad	4	+	+	+	
2	5315-17-004-7747		PEN, CILINDRISCH, MET KOP, St, 6h11 x 18 x 15,5, vcad (deur- haak)	4	+	+	+	
3	5315-17-001-6765		PEN, SPLIT, St, 1,5 x 20 mm, gefosf	4	+	+	+	
4	5310-17-003-1135		RING, SLUIT-, St, 6,4 x 12 x 1,5 mm, vcad	4	+	+	+	
5	5315-17-003-6184		PEN, CILINDRISCH, MET KOP, St, 8h11 x 40 x 37, vcad (kabelschijf, trekkabel, slot, achterklep)	2	+	+	+	
6	5315-17-001-6643		PEN, SPLIT, St, 2 x 30 mm, gefosf	2	+	+	+	
7	5315-17-004-7752		PEN, CILINDRISCH MET KOP, St, 10h11 x 30 x 26 mm, vcad	8	+	+	+	
8	5315-17-001-6660		PEN, SPLIT, St, 3 x 20 mm, gefosf	8	+	+	+	
9	5315-17-003-6185		PEN, CILINDRISCH, MET KOP, St, 16h11 x 80 x 75, vcad (kabelschijf lierkabel, achterklep a/hoekrong)	2	+	+	+	
10	5315-17-001-6675		PEN, SPLIT, St, 4 x 30 mm, gefosf	2	+	+	+	
11	5310-17-003-1133		RING, SLUIT-, St, 17 x 30 x 3 mm, vcad	2	+	+	+	
12			RIEMSCHIJF, GEGROEFD, lierkabel, achterklep (H0001//158953)	2				
13			RIEMSCHIJF, GEGROEFD, trekkabel, grondel, achterklep (H0001//353707)	2				
14			SLINGER, lier, achterklep (H0001//183199)	1				
15	5306-17-007-7546		BOUT, ZESKANT, St, 3/8 in x 24 UNF-2A x 2.1/2 in, vcad (gat van 3 mm ter plaatse boren)	1	+	+	+	
16	5310-17-024-2958		MOER, ZESKANT, St, 3/8 in x 24 UNF-2B, vcad	1	+	+	+	
17	5315-17-001-6664		PEN, SPLIT, St, 3 x 30 mm, gefosf	1	+	+	+	

Detaillijst NSN 2330-17-022-0065

Volgnr	Artikelnummer		Artikelomschrijving	aantal gemon- teerd	2e ech	3e ech	4e ech	Opmerkingen
	NATO Stocknummer	Fabrieksnummer						
	1	2						
			GROEP 22 - OPBOUW en ROMPTOEBEHOREN 2201.00 - ZEILEN (alleen voor NSN 2330-17-022-0066)					
1			DEKKLEED (H0001//180214)	1	+	+	+	za r
2	4020-17-003-1925		TOUW, GESLAGEN, MANILLA, omtrek ± 32 mm (L 62400 mm)	nb	+	+	+	per meter int
			2202.00 - REFLECTOREN					
3	9905-17-017-7740		REFLECTOR, VERKEERSBEBAKENING (rood)	10	+	+	+	
4	9905-17-017-7741		REFLECTOR, VERKEERSBEBAKENING (wit)	2	+	+	+	
5	5310-17-017-4764		MOER, ZESKANT, St, nr 5 x 40 NC-2B, vcad	36	+	+	+	
6	5310-17-003-7981		RING, VEER-, RECHT, St, B3.5, gezwart	36	+	+	+	
7	5305-17-007-2429		SCHROEF, BOLKOP, St, nr 5 x 40 UNC-2A x 5/8 in	36	+	+	+	
8	9905-17-017-7734		TEKEN (lengtedriehoek)	2	+	+	+	
9	5310-17-022-1832		MOER, ZESKANT, St, M4, vcad	6	+	+	+	
10	5310-17-006-1854		RING, VEER-, RECHT, St, B4	6	+	+	+	
11	5305-17-003-5787		SCHROEF, CILINDERKOP, St, AM 4 x 10, vcad	6	+	+	+	
			2210.00 - INSTRUCTIE- en IDENTIFICATIEPLATEN					
12	9905-17-017-7738		PLAAT, IDENTIFICATIE, afmetingen (H0001//143647)	1				
13	2540-17-007-2197		PLAAT, IDENTIFICATIE, chassisnummer	1				
14			PLAAT, INSTRUCTIE, bandendruk (H0001//143649)	1				
15			PLAAT, INSTRUCTIE, gewichten (H0001//143651)	1				
16	5320-17-015-4303		NAGEL, KLINK, MASSIEF, cu, 1/8 x 5/16 in	16				

NATO-STOCKNR	FABRIEKSNR	BLADZIJDE NR	ARTIKELVOLGNR
1	2	3	4
1025-00-523-8166	H0001//148323 06853//202735	37	11
2330-17-007-6076	H0001//145084	19	17
2510-17-003-2398	H0001//143289	76	4
2510-17-003-4016	H0001//1.870x4	45	1
2510-17-003-5942	H0001//152482	49	6
2510-17-007-2556	H0001//152485	50	7
2510-17-007-2602	H0001//135938	47	2
2510-17-007-9342	H0001//143291	46	19
2510-17-007-9343	H0001//136585	46	20
2510-17-015-1956	H0001//146206	49	14
2510-17-015-2011	H0001//152490	49	13
2510-17-017-2469	H0001//136593	46	16
2510-17-017-2471	H0001//136592	46	14
2510-17-017-2473	H0001//136591	46	13
2510-17-017-2481	H0001//136580	46	15
2510-17-017-7492	H0001//142644	46	7
2510-17-023-1425	H0001//151018	47	3
2510-17-023-1437	H0001//122033	47	9
2510-17-023-5219	H0001//145124	48	7
2510-17-024-0597	H0001//139876	47	1
2510-17-024-0713	H0001//3204030	46	8
2520-17-002-2787	H0001//121569	17	14
2520-17-630-1956	D8096// 002.999.01.014 H0001//144543	38	9
2530-00-447-1107	06853//212108 00000//538825	42	5
2530-00-270-3878	06853//220636	41	15
2530-00-350-6492	H0001//143944 06853//221574	29	1
2530-00-353-0485	H0001//148314 06853//233794	36	11
2530-00-426-8375	H0001//148257 06853//230108	28	5
2530-00-447-1145	H0001//148354 06853//221135	34	7
2530-00-523-8212	H0001//148252 06853//221053	29	4
2530-00-741-7355	H0001//148345 06853//214398	38	3
2530-00-832-7579	H0001//148359 06853//232865	34 35	8 14

1	2	3	4
2530-17-001-8163	K0092//KL76712 H0001//136756	26	2
2530-17-001-9573	H0001//142320	32	4
2530-17-004-6250	H0001//144189	17	2
2530-17-004-6253	H0001//139658	17	1
2530-17-006-2293	U0042//2865 H0001//148444	42	13
2530-17-006-2294	U0042//2845 H0001//148443	42	9
2530-17-006-8725	H0001//146190	14	11
2530-17-007-2458	H0001//148360 06853//224174	33	11
2530-17-007-2464	06853//235257 H0001//154188	27	15
2530-17-007-2469	D8096//001.280.04.051 H0001//186395	32	12
2530-17-007-2479	H0001//139661	42	10
2530-17-007-2480		36	4
2530-17-007-2481	H0001//148327 06853//224173	36	3
2530-17-007-2483	H0001//154365	26	13
2530-17-007-2553	H0001//148326 06853//224172	40	13
2530-17-007-2930	H0001//154180	27	19
2530-17-007-6073	H0001//146085	17	9
2530-17-007-6082	06853//225645 H0001//154182	26	11
2530-17-015-0311	K0092//27347 H0001//47168	25	3
2530-17-015-0317	K0092//22410 H0001//139729	21	12
2530-17-015-0325	K0092//28753 H0001//139738	21	13
2530-17-015-0327	K0092//29185 H0001//139667	21	14
2530-17-015-0339	K0092//28799 H0001//139740	24	6
2530-17-015-0343	K0092//81528 H0001//150917	23	11
2530-17-015-0346	K0092//29452 H0001//139749	25	4
2530-17-015-5100	K0092//28729 H0001//139807	20	12
2530-17-015-5145	K0092//36607 H0001//139801	21	1
2530-17-015-5156	K0092//36608 H0001//139802	20	19
2530-17-015-5157	K0092//6729 H0001//132687	23	4

1	2	3	4
2530-17-015-5165	K0092//29829 H0001//139805	20	10
2530-17-015-5172	K0092//29772 H0001//139806	20	11
2530-17-017-3543	H0001//131483	18	2
2530-17-017-3550	H0001//131482	18	3
2530-17-017-6848	U0042//W2805/1 U0042//W4606/5	43	12
2530-17-017-7964	H0001//146879	43	8
2530-17-022-4660	H0001//316209	21	19
2530-17-022-4661	H0001//10.551D60 H0001//316206	43	6
2530-17-022-6597	H0001//833501	21	6
2530-17-023-0944	K0092//KL71482 H0001//198720	22	13
2530-17-023-5707	D8096//026.242.00.006 H0001//145620	35	10
2530-17-023-5708	D8096//025-242-02.011 H0001//145633	35	11
2530-17-024-6774		21	8
2530-17-027-3444	D8096//434.100.002.0 H0001//584886	32	6
2530-17-027-7647	K0092//22422 H0001//139731	25	8
2530-17-027-8002	K0092//SSB-458	24	12
2530-17-600-2288	06853//234362 H0001//154181	27	6
2530-17-600-2289	H0001//148363 06853//233810	36	12
2530-17-600-2290	H0001//148341 06853//233812	53	9
2530-17-600-2291	H0001//148334 06853//233807	36	8
2530-17-600-2337	H0001//148321 06853//234761	34	13
2530-17-601-0444	H0001//148302 06853//233795	35	13
2530-17-601-0445	H0001//148319 06853//233803	33	15
2530-17-601-3187	H0001//148251	29	6
2530-17-601-3202	H0001//148343 06853//204261	34	15
2530-17-611-5462	K0092//27411 H0001//154396	22	3
2530-17-611-5562	K0092//39899 H0001//139769	21	5
2530-17-611-5564	K0092//39762 H0001//139768	24	3

Detaillijst NSN 2330-17-022-0065
 NATO-STOCKNUMMER INDEX (vervolg)

1	2	3	4
2530-17-611-5568	K0092//32052 H0001//139760	25	1
2530-17-611-5585	K0092//6731 H0001//132684	22	14
2530-17-611-5592	K0092//22424 H0001//139732	23 24	12 13
2530-17-611-5593	K0092//29174 H0001//139743	24	13
2530-17-611-5594	K0092//29764 H0001//139753	20	13
2530-17-611-5595	K0092//30858 H0001//139754	24	5
2530-17-611-5596	H0092//29762 H0001//139752	20	6
2530-17-611-5597	K0092//29283 H0001//139747	21	9
2530-17-611-5600	K0092//S1001 H0001//139755	20	3
2530-17-611-5605	H0001//136504	22	8
2530-17-611-5618	K0092//29186 H0001//139744	20	2
2530-17-611-5619	K0092//28286 H0001//139735	20	1
2530-17-611-6504	K0092//6042 H0001//132688	22	16
2530-17-614-9327	K0092//29755 H0001//139751	24	1
2530-17-630-1526	D8096//001.284.01.066 H0001//144809	32	16
2530-17-630-1528	D8096//005.290.03.070 H0001//186396	33	7
2530-17-630-1917	D8096//011.997.00.008 H0001//346573	37	6
2530-17-630-1918	D8096//022.996.00.0001 H0001//144527	40	10
2530-17-630-1919	D8096//025.242.00.176 H0001//144535	35	6
2530-17-630-1920	D8096//022.997.00.001 H0001//144536	37	12
2530-17-630-1921	D8096//002.292.00.021 H0001//144542	36	9
2530-17-630-1922	D8096//001.996.00.036 H0001//144552	40	2
2530-17-630-1923	D8096//113.996.00.001 H0001//145621	40	8
2530-17-630-1924	D8096//024-996-01-001 H0001//145624	40	11
2530-17-630-1926	D8096//026.242.00.078 H0001//145626	37	4

1	2	3	4
2530-17-630-1927	D8096//026.242.01.078 H0001//145627	37	5
2530-17-630-1928	D8096//026.242.00.116 H0001//145628	39	11
2530-17-630-1929	D8096//097.996.00.001 H0001//145637	40	9
2530-17-630-2064	D8096//025.242.01.221 H0001//144960	41	1
2530-17-630-2065	D8096//026.240.00.060. H0001//145622	35	17
2530-17-630-2066	D8096//026.242.00.041 H0001//145623	41	14
2530-17-630-2067	D8096//026.242.00.196 H0001//145629	37	3
2530-17-630-2068	D8096//051.240.01.061 H0001//145634	41	13
2530-17-630-2069	D8069//050.232.01.056 H0001//145636	39	14
2530-17-630-2639	D8096//002.2900.00.070 H0001//144812	33	6
2530-17-630-8331	D8096//026.240.00.001 H0001//146755	38	16
2530-17-631-0554	D8096//012.996.00.001 H0001//144813	33	4
2530-17-631-0556	D8096//001.284.01.076 H0001//144693	33	3
2530-17-631-0558	D8096//001.284.01.081 H0001//144691	33	8
2530-17-631-0560	D8046//001.280.00.052 H0001//144811	32	11
2530-17-631-0561	D8096//001.284.02.071 H0001//144694	32	13
2530-17-631-0713	D8096//025.242.02.151 H0001//145625	35	8
2530-17-706-9045	H0001//554130 H0099//Svtg13018	27	11
2530-17-707-4258	K0092//6042 H0001//132688	22	11
2530-17-800-7795		34	9
2540-17-004-6865	H0001//153051	49	9
2540-17-007-2197	H0099//Svtg61/2.5 16		
2590-17-003-7212	H0001//04N1862 H0007//EHDG 18	47	5
2590-17-007-6075	H0001//11.660x1 H0001//355378	44	15
2590-17-007-6080	H0001//158941	52	8
2590-17-007-6081	H0001//145559	12	8
2590-17-600-2338	06853//232846 H0001//154191	27	7
2610-17-002-9823	H0001//14N900	73	13

1	2	3	4
2610-17-029-8404	H0001//12N90012M	43	14
2640-17-003-7617	H0001//14N218279	43	19
2640-17-022-5329	H0001//15N003	43	18
2640-17-701-7173	00000//0520944	43	16
2815-17-007-6563	H0001//148310 06853//234559	39	10
2910-17-015-9891	H0001//122352 H0099//3420/F	23	5
3020-17-003-4692	H0001//146675	19	12
3040-17-601-4576	H0001//148335 06853//233808	35	3, 5
3110-00-100-0329	78500//K572 00000//706687	42	15
3110-00-100-0380	70500//K3920 00000//706771	42	14
3110-00-100-3095	78500//K3984 00000//705322	43	1
3110-17-022-1081	K0092//K19607 H0001//620G18V13	20	14
3110-17-605-8397	H0001//622V3 78500//575S	43	2
3120-17-001-8330	H0001//121425	18	16
3120-17-004-6888	H0001//20104141	50 53	6 9
3120-17-015-0580	H0001//927N025	18	17
3120-17-015-0582	H0001//927N030	18	18
3120-17-022-3072	H0001//128573	24	8
3830-17-007-6294	H0001//149108	53	10
4010-17-024-2162	H0001//432V13	18	4
4010-17-025-8342	H0001//346219	53	4
4010-17-026-1241	H0001//423N079 H0099//3556	53	5
4020-17-003-1925	00000//21.R.373 H0001//120856	55	2
4030-00-233-9567	00000//570501	53	6
4030-17-015-0296	H0001//149124 H0099//3030	19	15
4030-17-025-9601	00000//507404 H0001//146143	18	10
4030-17-026-1233	H0001//204353 H0001//181897	18	5
4340-17-706-4318	H0001//148253 06853//214171	29	5
4710-00-277-5526	00000//44-T-5080-20 24617//310952	26	1
4710-00-277-5527	00000//44T-5080-25 H0001//346817	30	11
4710-17-017-0143	H0001//346818	31	1
4710-17-017-0154	00000//44T.5080-15	25	16

1	2	3	4
4710-17-026-1675	H0001//309514 H0099//Svtg4215	31	2
4720-17-015-1955	H0001//143504 06853//215709	29	15
4720-99-943-9437	H0099//Svtg2136 H0001//208467	31	3
4730-00-044-4691	00000//444691	27	17
4730-00-278-5492	H0001//155093 06853//203755	31	8
4730-00-354-7802	06853//213630 00000//538824	42	4
4730-00-447-1106	06853//212107 00000//538826	42	6
4730-00-522-8623	H0001//143498 06853//205730	30	5
4730-17-003-5944	H0001//145228	22	9
4730-17-003-5953	H0001//145217	30	3
4730-17-003-5954	H0001//152988	30	2
4730-17-003-5956	H0001//851N315	30	1
4730-17-003-6710	D0917//2730232900 K0092//464 03477//FC269	25	14
4730-17-003-7358	H0099//Svtg4414 H0001//370N121/03	29	12
4730-17-003-7950	H0001//85011415 H0099//Svtg4425	30	6
4730-17-004-7223	D8096//8935-070-060-4 H0001//849N315	31	9
4730-17-007-1812	00000//504208 H0001//693N110	45	3
4730-17-007-6078	H0001//145220	35	2
4730-17-007-6546	K0092//10542/4 H0001//817N206	25	9
4730-17-015-1963	H0001//143500 06853//205829	29	14
4730-17-015-1966	H0001//143501 06853//205102	29	13
4730-17-015-1993	K0092//18234/4 H0001//817N108	26	10
4730-17-015-2261	H0001//146184 06853//215710	30	7
4730-17-015-2268	H0001//144022 06853//217691	28	3
4730-17-015-2269	H0001//143499 06853//205053	28	
4730-17-015-2278	H0001//144020 06853//217690	28	2
4730-17-015-5657	H0001//154253 06853//200361	28	8
4730-17-015-5658	H0001//155092 06853//203754	28	9
4730-17-015-5659	H0001//154252 06853//200360	31	7

1	2	3	4
4730-17-015-7510	H0001//132798 D8015//Sv Mr2502/1X	28	10
4730-17-024-2010	H0099//Svtg3243/1 H2428//CR26.5.19,5	24	7
4730-17-025-1727	00000//444688 06853//230178	27	16
4730-17-026-3165	H0001//132797 H0001//849N215	29	11
4730-17-600-2294	H0001//148351 06853//213230	39	15
4730-17-600-2298	H0001//148308 06853//233057	40	1
4730-17-600-2300	H0001//148258 06853//230111	31	4
4730-17-600-2302	H0001//148305 06853//233800	34	4
4730-17-600-2310	H0001//148329 06853//233813	39	16
4730-17-600-2312	H0001//148344 06853//233814	34	6
4730-17-600-2320	06853//232871 H0001//154190	27	5
4730-17-600-3910	06853//220165 00000//501658	42	3
4730-17-601-4570	H0001//339212 06853//239216	34	5
4730-17-611-5626	K0092//KL-7965/4 H0001//132368	26	5
4730-17-802-7751	H0001//149442 06853//205134	30	4
4820-17-007-6555	H0001//148336 06853//233805	36 41	7 8
4820-17-007-6556	H0001//148320 06853//233801	36	13
4820-17-007-6557	H0001//148337 06853//234243	36 41	6 10
4820-17-007-6558	H0001//148339 06853//233819	41	5
4820-17-007-6560	H0001//148346 06853//232032	41	7
4820-17-007-6561	H0001//18313 06853//232069	39	4
4820-17-007-6562	H0001//148318 06853//234558	35	16
4820-17-007-6564	H0001//148311 06853//234557	41	12
4820-17-007-6565	H0001//148303 06853//233937	35	1
4820-17-007-6566	H0001//148301 06853//224170	38	15

NATO-STOCKNUMMER INDEX (vervolg)

1	2	3	4
4820-17-600-3930	H0001//339205 06853//227361	38	10
4820-17-601-3856	H0001//304331 06853//238026	34	16
4820-17-601-4574	H0001//304349 06853//238127	34	14
4820-17-601-4575	H0001//304352 06853//238039	41	6
4820-17-601-4577	H0001//304328 06853//227350	38	14
4820-17-601-4578	H0001//304334 06853//237606	41	11
4820-17-601-4581	H0001//304337 06853//237605	35	15
4820-17-601-4582	H0001//304342 06853//228838	40	12
4820-17-601-4583	H0001//304343 06853//22735	36	2
4820-17-601-4505	H0001//304346 06853//238030	41	9
4820-17-601-4586	H0001//304347 06853//238032	41	4
4820-17-630-1748	D8015//SVSR5G 1Z H0001//316205	31	10
5110-17-022-2321	H0001//145187 H0206/9A	9	12
5140-17-007-4669	H0001//145510	47	13
5305-00-012-4064	00000//124064	51	7
5305-00-361-5112	63477//FD372 H0001//695E1	22 27	19 11
5305-17-003-5787	H0001//256N410 D8286//AM4x10DIN84-4S	14 55	16 11
5305-17-003-5867	D8286//M5x18DIN84	44	4
5305-17-003-5879	D8286//AM5x30DIN84-4S H0001//256N530	51	13
5305-17-004-7740	H0001//150783	44	16
5305-17-005-3597	D8286//AM6x12DIN84-4S H0001//256N612	11 32	14 15
5305-17-007-2429	00000//421575	55	7
5305-17-017-4696	H0001//231N1613	17	8
5305-17-017-7404	H0001//153654	11	9
5305-17-017-9378	H0001//218N20625	49	12
5305-17-017-9648	00000//420690	50 51	9 4
5305-17-022-8562	H0001//256N420 D8286//M4x20DIN84-4S	9 13	8 15
5305-17-611-5663	K0092//32253 H0001//139761	23	15
5305-17-611-5679	K0092//28290 H0001//139736	23	14
5305-99-941-0529	H0001//273N832	9	13
5306-00-012-0231	00000//120231	49	20

1	2	3	4
5306-00-012-6385	00000//126385	52	9
5306-00-043-2768	00000//432768	12	12
5306-17-001-6858	H0001//263V38 H0001//325440	45	16
5306-17-001-7409	H0001//273N1225 00000//181696	44	7
5306-17-001-7415	00000//181648 H0001//263N1050	52	2
5306-17-001-7417	00000//181639 H0001//273N1032	38 47	11 10
5306-17-003-2832	H0001//148246	52	1
5306-17-003-3860	H0001//144879	46	11
5306-17-003-6349	H0099//4053/2 H0001//276N05010	17	6
5306-17-003-6385	D8286//M8x30DIN931-8G	35	12
5306-17-004-6376	H0001//288N06038	48 50 51	5, 8 14 1, 15
5306-17-004-6957	H0001//145562	12	9
5306-17-006-7107	H0001//273N616	9 10 18 48	2 1 7 1
5306-17-007-7400	00000//180079	28 33 34	6 12, 16 2
5306-17-007-7402	96906//90725-40	40	14
5306-17-007-7407	00000//180122 H0001//272N1025/03	29	2
5306-17-007-7417	00000//180175 H0001//272N1232/03	42	11
5306-17-007-7520	H0001//273N612/03 00000//181561	14 13 29	10 17 9
5306-17-007-7523	00000//181567 H0001//273N622	16	10, 14
5306-17-007-7525	00000//181573	49 51	4 11
5306-17-007-7532	H0001//273N825 00000//181608	44 46 53	12 9 11
5306-17-007-7541	00000//181636 H0001//273N1022	25 48	2 14
5306-17-007-7546	00000//181650 H0001//263N1064	54	15
5306-17-007-7547	H0001//273N1076 00000//181652	49 52	5 5
5306-17-007-7552	H0001//263N1132	21	2

1	2	3	4
5306-17-007-7556	00000//181698 H0001//273N1232	44	8
5306-17-007-7557	00000//181700 H0001//273N1238	53	15
5306-17-007-7568	00000//271744 H0001//273N16 38/	21	5
5306-17-015-9041	00000//181618 96906//90726-39	18 39	12 1
5306-17-015-9047	00000//181558 H0001//273N610	25	12
5306-17-015-9058	00000//181635 H0001//273N1019/03	22 27 47	4 12 14
5306-17-017-4239	00000//181643 H0001//263N1038/03	47 48	15 9
5306-17-022-0591	H0001//120741 00000//181595	53	2
5306-17-022-0702	H0001//149472	22	1
5306-17-022-0800	H0001//144695 D8286//M81.35DIN564-5S	32	9
5306-17-022-5031	H0001//259N12210	45	6
5306-17-024-2931	96906//90725-12	50 52	3 12
5306-17-024-3002	00000//181580	51	6
5306-17-024-3419	H0001//316015	45	8
5306-17-600-2309	H0001//148325 06853//203388	40	15
5306-17-600-2316	06853//234145 H0001//154185	27	3
5306-17-611-5670	K0092//24681 H0001//139734	20	9
5306-17-611-5678	K0092//K18201 H0001//324730	23	16
5306-17-611-5681	K0092//31190 H0001//325295	24	4
5306-17-706-2177	K0092//29258 H0001//139668	20	8
5307-17-022-1415	H0001//139479	43	9
5307-17-023-4169	H0001//142886	26	8
5307-17-600-2317	06853//235255 H0001//154186	27	1
5307-17-600-2318	06853//212187 H0001//154187	26	16
5310-00-010-3323	H0001//453N112 00000//103323	46	2
5310-00-050-3331	04636//914007 H0001//320659	47	6
5310-00-285-7084	96906//20365-1216A 96906//51922-61	46	12

1	2	3	4
5310-00-361-7052	63477//FC17 H0001//972V12	23	2
5310-17-001-7712	00000//125224 H0001//208N108/03	18	13
5310-17-002-0309	H0001//453N106 H1266//N1197-B-L-67	9 10 14 16 18 25 29 32 42 48 50 51 52	4 3 1, 4, 12 12, 16 9 3 10 14 2 3 5 9 4
5310-17-002-6270	00000//120375 96906//25690-402	48 50 51	6, 10 4, 15 2, 13, 16
5310-17-003-1133	D8286//17DIN125 H0099//4033	54,	1, 11
5310-17-003-1135	D8015//2916 011014 D8286//6.4DIN125	50 54	12 4
5310-17-003-1138	D8286//21DIN125	49	8
5310-17-003-1142	D8286//10.5DIN125 H0001//202817	19 47 49	5 11 11
5310-17-003-3852	H0001//346630	23	1
5310-17-003-6143	D8286//13.5DIN433 D8286//13.5x21x2DIN433	17	13
5310-17-003-6144	D8286//15DIN433 H0001//325026	19	11
5310-17-003-6145	H0001//132795 H0001//455N310 103	19	4
5310-17-003-6147	D8286//13DIN433 H0001//455E26	19	8
5310-17-003-6149	D8286//8.4DIN433 H0001//455N308/03	33 34 40	14, 17 3 16
5310-17-003-7283	H0001//325377	19	14
5310-17-003-7284	H0001//325291	47	7
5310-17-003-7544	D8286//26DIN1441 H0001//325031	19	13
5310-17-003-7978	D8286//B12DIN127	21	4
5310-17-003-7979	D8286//B10DIN127 H0001//453N110	22 27 29 38 47 48 49 52	2, 8 14 3 13 12, 18 12, 16 17 3, 7
5310-17-003-7981	D8286//B3.5DIN127 96906//35338-22	55	6
5310-17-003-7983	H0001//451N105 H0001//453N105	44	3

1	2	3	4
5310-17-003-7984	D8286//B14DIN127 H0001//453N112	26	4
		53	17
5310-17-003-7998	H0001//325292	47	8
5310-17-003-8211	H0001//455N025 H0001//324026	45	10
5310-17-003-8217	H0001//455N008 D8286//8.4DIN125	18	15
		53	3
5310-17-004-7783	D8286//M8DIN934-6S D8286//5245	32	10
5310-17-006-1854	H0001//451N104 D8286//B4DIN127	9	7
		13	14
		55	10
5310-17-015-1324	H0099//2091 H0001//325017	26	7
5310-17-015-1358	H0001//198922 H0099//Svtg2087	20	5
5310-17-015-5361	H0001//455V42/03	52	17
5310-17-015-6340	00000//120376 H0001//202N108	50	1
		52	10
5310-17-015-7108	D8286//M5DIN934-6S H0001//206N105/03	44	2
5310-17-015-7626	00000//121358 H0001//203N116	26	14
5310-17-015-8546	00000//120613 H0001//1203N206	18	8
		49	5, 16
		51	8, 12
		52	16
5310-17-015-8581	K0092//K24105 H0001//203N212/03	20	4
		23	6
		26	3
5310-17-015-8974	00000//432769 23000//33797-316	12	13
5310-17-015-9586	H0001//10N316013 D8286//C20.5DIN74361	43	5
5310-17-017-0230	H0001//203N11cd 00000//271506	21	3
5310-17-017-2426	24617//125043 H0001//208N212/03	17	11
5310-17-017-2428	00000//125215 H0001//208N106	36	15
5310-17-017-4764	00000//426324	55	5
5310-17-017-6308	D8286//A5.3DIN6798 H0001//451N205	17	7
5310-17-017-9932	00000//120371 H0001//203N112	18	1
		45	7
		46	1
		53	16
5310-17-017-9933	H0001//203N106 00000//120367	9	3
		10	2
		14	11
		42	1
		48	2

1	2	3	4
5310-17-017-9937	00000//120368 H0001//203N108/03	27	4
		39	2
		41	13
		50	8
		51	3
		53	12
5310-17-022-1803	H0001//207G5 cd H0001//324636	43	4
5310-17-022-1832	H0001//206N104 D8286//M4-DIN954-6S	9	6
		13	12
		55	9
5310-17-022-1855	H0001//207C6 D8286//M20x1.5DIN934-6S	43	10
5310-17-022-2325	H0001//290N125 00000//503N404	45	9
5310-17-024-2958	00000//120369 H0001//203N110	26	6
		27	13
		32	2
		38	12
		47	11, 16
		48	11, 15, 16
		52	6
		54	16
5310-17-025-5663	D8286//A8.4DIN6798 H0001//451N208	44	14
		53	13
5310-17-026-0110	H0001//145558	12	11
5310-17-026-2306	H0001//453N212 H0001//453N212/03	42	12
		44	10
5310-17-026-3972	D8286//B8DIN127 H0001//453N108 39	9	14
		28	7
		39	3
		40	10
5310-17-029-0275	D8286//13.5DIN125 H0001//455N012	23	7
		44	9
5310-17-600-2293	H0001//148353 06853//213229	39	6
5310-17-600-2297	H0001//148317 06853//232066	39	9
5310-17-600-2311	H0001//148333 06853//233809	39	7
5310-17-600-2313	H0001//148350 06853//233815	39	5
5310-17-600-2321	06853//235256 H0001//155090	27	8
5310-17-600-4480	78500//1229-G-1021 H0001//8.367D60	42	8
5310-17-600-4481	78500//1227-I-228 H0001//8.368060	43	3
5310-17-601-4567	H0001//339209 06853//238657	37	2
5310-17-601-4579	H0001//304335 06853//237598	39	8
5310-17-611-5660	K0092//29188 H0001//139745	21	11

1	2	3	4
5310-17-611-5662	K0092//32254 H0001//139762	24	11
5310-17-611-5666	K0092//31002 H0001//139756	21	10
5310-17-611-5667	K0092//209753 H0001//139750	24	10
5310-17-630-1695	D8096//005.292.01.031 H0001//183932	33	2
5310-17-631-6450	H0001//455N004/03 D8286//5DIN1440	13	13
5310-17-707-1151	H0001//453N116 D8286//B16DIN127	22 26	7 15
5310-17-800-7825	H0001//148355 06853//211541	34 41	11 3
5310-17-800-7826		34	10
5310-17-800-7827	H0001//148358 06853//211595	34 41	12 2
5315-17-001-6639	H0001//323N215 D8286//2x20DIN94	18 19 49	14 16 10
5315-17-001-6643	D8286//2x30DIN94 H0001//323N230	54	6
5315-17-001-6660	H0001//323N320 H0001//323N315	19 38 54	2 8 8
5315-17-001-6664	D8286//3x30DIN94 H0001//323W330	19 54	3 17
5315-17-001-6675	D8286//4x30DIN94 H0001//323N420	19 53 54	7, 10 19, 21 10
5315-17-001-6676	H0001//323N435 D8286//4x40DIN94	17 44	12 17
5315-17-001-6685	D8286//5x30DIN94 H0001//323N530/14	49	7
5315-17-001-6698	D8286//6x40DIN94 H0001//323N640	53	8
5315-17-001-6765	D8286//1.5x20DIN94 H0001//323N1520	36 50 54	16 11 3
5315-17-002-2684	H0001//322N0322	27	10
5315-17-003-6182	H0001//3184060	19	9
5315-17-003-6183	D8286//12h11x35DIN435 H0001//318N12035/03	19	6
5315-17-003-6184	H0001//318N08040 D8286//8h11x40x37DIN1435-St 50	54	5
5315-17-003-6185	D8286//16h11x80x75DIN1435	54	9
5315-17-003-6749	H0001//149973	48	17
5315-17-003-7872	H0001//319N16005	53	20
53 5-17-003-7952	D8286//4x20DIN1471	39	13
5315-17-004-7253	H0001//121134	19	1

Detaillijst NSN 2330-17-022-0065
NATO-STOCKNUMMER INDEX (vervolg)

1	2	3	4
		39	12
5315-17-004-7733	D8286//5x36DIN1473	50	10
5315-17-004-7747	D8286//6h11x18x15.5DIN1435	54	2
		54	7
5315-17-004-7752	H0001//318N10030	44	11
5315-17-024-4233	H0001//181852	20	17
5315-17-611-5620	K0092//22411 H0001//139730	20	18
5315-17-611-5621	K0092//22402 H0001//139727	24	16
5315-17-611-5661	K0092//KL40503 H0001//139771	20	16
5315-17-611-5672	K0092//22409 H0001//139728	38	6
5315-17-631-0625	D8096//025.242.03.181 H0001//145631	45	2
5320-17-003-3856	H0001//305V14	21	7
5320-17-003-6729	H0001//325294	46	5, 7
5320-17-005-9540	D8286//8x22DIN660		
5320-17-015-4303	00000//427079	16	7
5325-17-004-7230	H0001//909N103	16	8
5325-17-004-7224	H0001//909/N151	31	5
5325-17-004-7246	H0001//909N153	16	6
5325-17-004-7248	H0001//909N86	16	5
5325-17-004-7249	H0099//Svtg-3045 H0001//909N81	16	4
5325-17-616-7076	H0099//3195	30	8
5330-00-291-1975	H0001//148254 06853//230109	37	8
5330-00-640-9612	H0001//148330 06853//232068	37	16
5330-00-741-7359	H0001//148338 06853//232908	37	13
5330-17-002-0517	D8286//A48x55DIN7603fi H0001//918N202738	32	3
5330-17-003-1582	D8286//C22x27DIN7603 H0001//325275	30	10
5330-17-003-1590	H0001//325275 D8015//HMR52/112	16	1
5330-17-003-3979	H0001//138536	25	15
5330-17-003-7346	K0092//KL.44518 H0001//325015	43	17
5330-17-003-8181	H0001//14N01 H0099//14/8III	16	3
5330-17-003-9297	H0001//132432	37	10
5330-17-004-5461	H0001//145221	13	2
5330-17-004-8950	H0001//122437 H0099//B11		

1	2	3	4
5330-17-006-1595	H0001//132799 H0099//Svtg4428	30	9
5330-17-017-4599	H0001//121680 H0099//3114/2	43	7
5330-17-017-4602	H0001//324797	20	15
5330-17-024-2012	H0099//3145 H0001//929N5	32	5
5330-17-025-8729	H0001//158331 H1379//P1360-6	11	18
5330-17-026-0154	H0001//908N0091 H0099//2461	45	4
5330-17-600-2299	H0001//325435 06853//230895	37	7, 9
5330-17-600-2303	H0001//148306 06853//233797	38	2
5330-17-600-2306	H0001//148312 06853//214314	38	4
5330-17-600-2308	H0001//148322 06853//230175	37	15
5330-17-600-2319	06853//235260 H0001//154189	27	9
5330-17-601-3207		56	5
5330-17-601-4568	H0001//339210 06853//236304	37	14
5330-17-601-4569	06853//238107 H0001//339211	38	1
5330-17-601-4571	H0001//339213 06853//238376	38	5
5330-17-630-1660	D2342//WV4-2412/a H0001//147403	42	16
5340-17-001-3826	H0099//25x1.2Svtg4264 D8286//25x1.2DIN471	17	3
5340-17-001-7721	H0001//120037	31	11
5340-17-003-1873	D8286//20x1DIN472 H0001//457N3020	32	7
5340-17-003-1891	H0001//458N2030 D8286//30x1.5DIN471	17	4
5340-17-003-4031	H0001//156854	12	10
5340-17-003-4040	H0001//152914	50 52	2 11
5340-17-003-4298	H0001//150716	49	2
5340-17-003-4299	H0001//150715	49	1
5340-17-003-6733	H0001//361N012	25 29	11 7
5340-17-003-6735	H0001//361N008 H0099//Svtg1517/1	25	10
5340-17-003-6738	H0001//361N016 H0001//361N016/03	29	8
5340-17-003-7273	D8286//3.2DIN6799 H0001//458N3065	32	8

Detaillijst NSN 2330-17-022-0065
NATO-STOCKNUMMER INDEX (vervolg)

1	2	3	4
5340-17-003-9589	H0001//04N207503 H0007//151-180-04	47	3
5340-17-004-5462	H0001//148992	13	3
5340-17-004-5839	H0001//153656	13	5
5340-17-004-5840	H0001//324237	13	4
5340-17-004-6876	H0001//132497	49	3
		51	10
		17	10
5340-17-004-6887	H0001//146086	47	19
5340-17-006-8723	H0001//154356	50	16
5340-17-006-8726	H0001//152472	50	17
5340-17-006-8727	H0001//152474	50	13
5340-17-006-8728	H0001//152483	51	5
5340-17-006-8729	H0001//152997	51	14
5340-17-007-6290	H0001//200319E1	18	6
5340-17-007-6291	H0001//148429	20	7
5340-17-015-0310	K0092//KL40005 H0001//139689	23	13
		13	16
5340-17-015-1046	H0001//361N116	23	10
5340-17-015-5146	H0001//132686	14	2
5340-17-017-4581	H0001//462E8 H0001//324183	28	4
		32	3
5340-17-017-4611	H0001//324076 D0917//2730-2331.00	45	15
5340-17-017-5995	H0001//324054	49	19
5340-17-022-6122	H0001//150682	49	18
5340-17-022-6157	H0001//150683	46	3
5340-17-022-6562	H0001//316014	43	11
5340-17-023-1503	H0001//419 G 52 H0001//324750	46	17
		46	18
5340-17-025-0145	H0001//139942	48	4
5340-17-025-0146	H0001//139865	40	4
5340-17-025-4724	H0001//150370	40	4
5340-17-600-2292	H0001//148352 06853//213223	40	7
5340-17-600-2296	H0001//148342 06853//232034	33	10
5340-17-600-2301	H0001//148304 06853//233938	40	6
5340-17-600-2304	H0001//148307 06853//234650	40	5
5340-17-600-2305	H0001//148309 06853//211170	27	18
5340-17-600-2314	06853//234365 H0001//154178	27	2
5340-17-600-2315	06853//224779 H0001//154184	40	5
534 -17-601-4573	H0001//304348 06853//234839		

1	2	3	4
5340-17-610-3168	H0001//148340 06853//233806	35	7
5340-17-611-5628	K0092//22348 H0001//132680	23	9
5340-17-611-5630	K0092//27417 H0001//132679	23	8
5340-17-611-5664	K0092//32003 H0001//139759	25	6
5340-17-611-5665	K0092//31.431 H0001//139757	21	17
5340-17-611-5668	K0092//29383 H0001//139748	25	5
5340-17-611-5669	K0092//28931 H0001//139741	21	18
5340-17-611-5671	K0092//23772 H0001//139733	21	15
5340-17-611-5676	K0092//29289 H0001//139669	21	16
5340-17-630-1683	D8096//013.996.00.001 H0001//144692	33	5
5340-17-630-1686	D8096//002.292.00.031 H0001//144814	33	1
5390-00-597-0305	06853//212109	42	7
5640-17-003-4679	H0001//148990	13	1
5920-17-001-3721	D2598//1621/E27	9	9
5920-17-002-6665	D8286//DIN49360/E27/6	9	10
5920-17-002-6666	D8286//DIN49360/E27/15	9	11
5935-00-699-7827	H0099//111/1 00000//8376209	16	9
5935-17-003-3953	H0001//145189	9	1
5940-17-001-9505	H0050//TWP81N H0001//120267	12	5
5940-17-001-9506	H0050//TWP81P H0001//81P	12	6
5940-17-003-7142	H0001//525N40105 H0099//3088	13	8
5940-17-003-7143	H0001//525N40106	13	9
5940-17-023-0557	H0099//42/1 H0001//122 471	13	11
5940-17-709-1789	H0001//525N40406 H0099//Svtg3998(1.5)	13	10
5970-17-026-1160	H0099//Svtg4490 H0001//517N8	14	13
5975-17-003-3952	H0001//125277	16	2
5975-17-003-7144	H0001//515N0458	15	7
5975-17-003-7145	H0001//515N0457	15	6
5975-17-003-7147	H0001//515N0456	15	5
5975-17-003-7166	H0001//515N04591	15	16
5975-17-003-7167	H0001//515N04581	15	13
5975-17-003-7169	H0001//515N04596	15	18
5975-17-003-7174	H0001//515N04595	15	17

Detaillijst NSN 2330-17-022-0065
 NATO-STOCKNUMMER INDEX (vervolg)

1	2	3	4
5975-17-003-7175	H0001//515N04586	15	15
5975-17-003-7176	H0001//515N04585	15	14
5975-17-003-7177	H0001//515N04580	15	12
5975-17-003-7229	H0001//515N0459	15	8
5975-17-004-5841	H0001//515N04057	15	2
5975-17-004-5842	H0001//515N04056 H0050//400-056	15	1
5975-17-004-5843	H0001//515N046/1	15	9
5975-17-004-5848	H0001//515N04110/1	15	19
5975-17-004-5849	H0001//515N04110/2	15	20
5975-17-004-5850	H0001//515N04110/3	15	21
5875-17-004-5851	H0001//515N046/2	15	10
5975-17-022-0959	H0001//515N04074 H0050//400-074	15	4
5975-17-022-0960	H0001//515N04073 H0050//400-073	15	3
5975-17-022-1926	H0050//400-90 H0001//515N0490	15	11
5975-17-022-2402	H0001//514N15 H0050//217	14	14
5975-17-640-0025	H0578//1010 H0001//129701	14	17
6130-17-707-2699	H0002//PHE1347 H0001//N4841	12	14
6140-17-025-8169	H0099//124	12	7
6145-17-001-9627	H0001//504N10408 H0099//11040ZW	14	7
6145-17-006-2525	H0099//Sv tg 19a/1.5 H0099//11015ZW	14	8
6145-17-025-0979	H0099//43015 ZW	14	16
6145-17-616-7092	H0009//120 15 Z	14	15
6220-17-007-1564	H0001//134340 H1379//1330 A	11	12
6220-17-015-5301	H0001//154645 H0001//P1360	11	15
6220-17-023-0552	H1379//S-1050 H0099//5331	11	16
6220-17-023-2944	H1379//1330-9 H3067//6023-22	11	8
6220-17-023-3021	H1379//P1360-5 H0001//158332	10	6
6220-17-023-3023	H0099//5337 H0001//204493	10	7
6220-17-023-3044	H1379//1320.1 06815//LFE81-92Z	10	5
6220-17-025-0854	H1379//1320 H0099//75/3	11	11
6220-17-025-8349	H0001//145190	9	15

NATO-STOCKNUMMER INDEX (vervolg)

1	2	3	4
6240-17-005-3376	H0002//13821	10	9
6240-17-005-9576	H1650//X54.1 blad 7	10	11
6240-17-006-6924	H0002//13445 H0001//561473	10	10
6240-17-024-4082	H0002//6445	10	8
6810-17-033-3666	H0001//134144	13	7
8305-17-024-2033	H0099//Svtg3145/2 H0001//354480	13 26 31	6 9 6
9320-17-706-8743	H0001//327037	45	4
9905-17-017-7734	H0099//65B/2 H0001//302000	55	8
9905-17-017-7740	H0001//120379 H0099//Svtg 65/03	55	3
9905-17-017-7741	H0099//Svtg 65/AS H0001//120378	55	4

Detaillijst NSN 2330-17-022-0065

FABRIEKSNUMMER INDEX (vervolg)

1	2	3	4	5	6
06853//205102	29	13	06853//224174	33	11
06853//205134	30	4	06853//224719	27	2
06853//205730	30	5	06853//225645	26	11
06853//205829	29	14	06853//227350	38	14
H0001//206N104	9	6	06853//227361	38	10
	13	12	06853//227735	36	2
	55	9	06853//228656	35	5
H0001//208N106	36	15	06853//228838	40	12
H0001//208467	31	3	06853//230107	29	6
06853//211170	40	5	06853//230108	28	5
06853//211541	41	3	06853//230109	30	8
06853//211542	37	1	06853//230111	31	4
05853//211595	41	2	06853//230175	37	15
06853//212107	42	6	06853//230178	27	16
06853//212108	42	5	06853//230895	37	9
06853//212109	42	7	H0001//231N1613	17	8
06853//212187	26	16	06853//232032	41	7
06853//2132277	36	10	06853//232034	40	7
06853//213228	40	4	06853//232066	39	9
06853//213229	39	6	06853//232068	37	8
06853//213230	39	15	06853//232846	27	7
06853//213630	42	4	06853//232865	34	8
06853//214171	29	5		35	14
06853//214314	38	4	06853//232871	27	5
06853//214398	38	3	06853//232908	37	16
06853//215709	29	15	06853//233057	40	1
06853//215710	30	7	06853//233794	36	11
06853//217690	28	2	06853//233795	35	13
06853//217691	28	3	06853//233797	38	2
H0001//218N20625	49	12	06853//233800	37	4
06853//220165	42	3	06853//233801	36	13
06853//220636	41	15	06853//233803	33	15
06853//221053	29	4	06853//233804	36	1
06853//221135	34	7	06853//233805	41	8
06853//221474	29	1	06853//233806	35	7
06853//224170	38	15	06853//233807	36	8
06853//224172	40	13	06853//233808	35	3
06853//224173	38	3			

Detaillijst NSN 2330-17-022-0065

FABRIEKSNUMMER INDEX

FABRIEKSNR	BLADZIJDENR	ARTIKEL- VOLGNER	FABRIEKSNR	BLADZIJDENR	ARTIKEL- VOLGNER
1	2	3	4	5	6
H0206/9A	9	12	H0099//Svtg 19a/1.5	14	8
H0099//B11	13	2	H0001//20765 cd	43	4
63477//FC17	23	2	H0001//20766	43	10
H0007//EHDG 18	47	5	H0099//Svtg 2087	20	5
D8015//SVSR5G1Z	31	10	H0099//2091	26	7
H0099//Svtg 65/AS	55	4	H0099//Svtg 2136	31	3
H0001//81P	12	6	H0099//2461	45	4
H0050//TWP81N	12	5	U0042//2845	42	9
H0050//TWP81P	12	6	U0042//2865	42	13
D8015//LBF11/2X	11	5	H0099//3030	19	15
H0099//124	12	7	H0099//Svtg 3045	16	5
H0099//14/8 III	43	17	H0099//3088	13	8
H0050//217	14	14	H0099//3145	32	5
03477//FC269	25	14	H0099//Svtg 3145/R	26	9
63477//FD372	22	9		31	6
	24	15	H1009//3185	9	5
H0099//42/1	13	11	H0099//3195	16	4
D8015//LFE43/3X	10	4	H0099//3556	53	5
K0092//464	25	14	78500//K3920	42	14
K0092//SSB-458	24	12	78500//K3984	43	1
78500//K572	42	15	H0099//4033	54	1
78500//575S	43	2		54	11
H0099//65B/2	55	8	H0711//4050	16	13
H0099//75/3	11	11	H0711//4051	44	1
K0092//S1001	20	3	D8286//B4DIN127	9	7
H0578//1010	14	17		13	14
H1379//S-1050	11	16	H0099//Svtg 4215	55	10
H1379//S1052	10	14		31	2
	11	1	H0099//Svtg 4414	29	12
H1379//S-1055	11	10	H0099//Svtg 4425	30	6
D8015//LPT109/2X	11	7	H0099//Svtg 4428	30	9
H0099//111/1	16	9	H0099//Svtg 4490	14	13
D8015//Q0129/3	11	3	H0001//462E8	28	4
H1379//1320	11	11	H0001//47168	25	3
H1379//1330 a	11	12	H0001//N4841	12	14
H0002//PHE1347	12	14	D8286//A0.5DIN125	47	17
H0001//P1360	11	15	H0001//517N8	14	13
H0001//14N01	43	17	D8286//5245	32	10
			H0099//5331	11	16

FABRIEKSNUMMER INDEX (vervolg)

1	2	3	4	5	6
H0099//5336	11	19	H0002//13445	10	10
H0099//5337	10	7	H1379//P-1360-1	11	7
H0099//5338	11	10	H1379//P-1360-2	12	3
H1650//X54.1 blad 7	10	11	H1379//P-1360-3	10	12
65909//A5986	43	16	H1379//P1360-5	10	6
K0092//6042	22	11	H1379//P-1360-6	11	18
	22	16	H0002//13821	10	9
D8286//B6DIN127	11	13	D8286//B14DIN127	26	4
H0001//622V3	43	2		53	17
H0002//6445	10	8	H0001//14N900	43	13
H0099//Svtg 65/03	55	3	H0001//15N003	43	18
K0092//6729	23	4	H0001//15N004	43	18
K0092//6731	22	14	H0099//Svtg 1517/1	25	10
H0001//695E1	22	19	D8286//15DIN433	19	11
	24	15	D8286//B16DIN127	22	7
D8286//B8DIN127	9	14		26	15
	38	7	D8286//17DIN125	54	1
	39	3		54	11
O8615//LFE81-92-Z	10	5	K0092//K18201	23	16
H0001//929N3	26	9	H0001//1.870x4	45	1
H0001//929N5	32	5	K0092//K19607	20	14
D8286//B10DIN127	22	6	H0001//203N11 cd	21	3
	27	4	K0092//20662	22	10
	38	13	K0092//21096	22	12
	47	12	D8286//21DIN125	49	8
	47	18			
	48	16	00000//21.R.373	55	2
	49	17	D8286//2x20DIN94	18	14
	52	3		19	16
	52	7		49	10
H0099//11015ZW	14	8	K0092//22348	23	9
H0099//11040ZW	14	7	K0092//22402	20	18
H0099//120 15 Z	14	15	K0092//22409	20	16
D8286//B12DIN127	21	4	K0092//22410	21	12
H0099//Svtg 13018	27	11	K0092//22411	20	17
H1379//1320.1	10	5	K0092//22422	25	8
H1379//1320-4	11	5	K0092//22424	23	12
H1379//1320-5	12	1	D8286//2x30DIN94	54	6
H1379//1320-3	11	17	K0092//23772	21	15
H1379//1320-8	12	2	K0092//K24105	20	4
H1379//1320-9	11	2		23	6
H1379//1330-9	11	8			
D8286//13DIN433	19	8			

Detallijst NSN 2330-17-022-0065

FABRIEKSNUMMER INDEX (vervolg)

1	2	3	4	5	6
K0092//24681	20	9	K0092//32052	25	1
D8015//Sv M _P 2502/1X	28	10	D8286//3x20DIN94	19	2
H0001//25953	23	3		54	8
H0001//263V38	45	16	K0092//32253	23	15
K0092//27347	25	3	K0092//32254	24	11
K0092//27411	22	3	H0099//Svtg 3243/1	24	7
K0092//27417	23	8	H0001//32690	22	10
H0042//W2805/1	43	12	D8286//3x30DIN94	19	3
K0092//28286	20	1		54	17
K0092//28290	23	14	D8286//B3.5DIN127	55	6
K0092//28729	20	12	K0092//36607	21	1
K0092//28753	21	13	K0092//36608	20	19
K0092//28799	24	6	K0092//38376	24	9
K0092//28931	21	18	K0092//39762	24	3
K0092//29173	24	2	K0092//39899	21	5
K0092//29174	24	13	K0092//KL40005	20	7
K0092//29185	21	14		23	13
K0092//29186	20	2	K0092//KL40503	24	16
K0092//29188	21	11	H0099//4053/2	17	6
K0092//29258	20	8	H0001//04N1862	47	5
K0092//29283	21	9	H0001//419652	43	11
K0092//29289	21	16	D2342//WV4-2412/a	42	16
K0092//29383	25	5	H0099//43015 ZW	14	16
K0092//29452	25	4	D8286//4x30DIN94	19	7
K0092//29753	24	10		19	10
K0092//29755	24	1		53	19
K0092//29763	20	6	H0001//432V13	53	21
K0092//29764	20	13		54	10
K0092//29772	20	11	D8286//4x40DIN94	18	4
K0092//29829	20	10		17	12
H0001//305V14	45	2		44	17
K0092//30858	24	5	K0092//KL44518	25	15
K0092//31002	21	10	H0001//45N108	39	3
H0099//3114/2	43	7	H0001//455E26	19	8
K0092//31190	24	4	U0042//W4606/5	43	12
K0092//31.431	21	17	D8286//M4DIN934-6S	9	6
H0099//Svtg 3145/2	13	6		55	9
K0092//31858	24	17	D8286//M4DIN954-6S	13	12
D8286//3x18x94	19	3	H0001//514N15	14	14
K0092//32003	25	6	D8286//5DIN1440	13	13
			D8286//M5x18DIN84	44	4
			D8015//HMR52/112	30	10
			D8286//5x30DIN94	49	7

FABRIEKSNUMMER INDEX (vervolg)

1	2	3	4	5	6
H0001//54190	27	5	00000//120368	27	4
D8286//M5DIN934-6S	44	2		39	2
D8286//6x40DIN94	53	8		44	13
D8286//6.4DIN125	50	12		50	8
	54	4		51	3
				53	12
K0092//KL71482	22	13	00000//120369	26	6
K0092//KL76712	26	2		27	13
K0092//KL7965/4	26	5		32	2
K0092//81528	23	11		38	12
D8286//8.4DIN125	18	15		47	16
	53	3		48	10
				48	11
D8286//8.4DIN433	33	14		49	16
	33	17		52	6
	34	3	00000//120371	54	16
	40	16		18	1
				45	7
D8286//M8DIN934-6S	32	10		46	1
H0001//909N81	16	5	00000//120375	53	16
H0001//909N86	16	6		48	6
H0001//972V12	23	2		48	10
00000//103319	18	9		50	15
	25	13		51	2
	29	10	00000//120376	51	16
	32	14		52	13
	42	2	H0001//120378	50	1
	48	3		55	4
	50	5	H0001//120379	55	3
	51	9	00000//120613	18	8
	52	14		49	5
				51	8
00000//103323	46	2		51	12
D8286//10.5DIN125	19	5		52	16
	49	1	H0001//120741	53	2
K0092//10542/4	25	9	H0001//120856	55	2
H1266//N1107-B-L-67	9	4	H0001//121134	19	1
H0001//11.660X1	44	15	00000//121358	26	14
H1266//N1197-B-L-67	10	3	H0001//121425	18	16
	14	1	H0001//121569	17	14
	14	4	H0001//121680	43	7
	14	12	H0001//122033	47	9
	16	12	H0001//122 352	23	5
	16	16	H0001//122437	13	2
	25	13	H0001//122454	11	3
H0001//120037	31	11	H0001//122 471	13	11
00000//120231	49	20	00000//123798	39	1
H0001//120267	12	5	00000//124064	51	7
00000//120367	9	3			
	42	1			
	48	2			
	52	10			

Detaillijst NSN 2330-17-022-0065

FABRIEKSNUMMER INDEX (vervolg)

1	2	3	4	5	6
00000//124934	26	3	H0001//136756	26	2
24617//125043	17	11	H0001//138536	16	1
00000//125215	36	15	H0001//139479	43	9
00000//125224	18	13	H0001//139658	17	1
H0001//125277	16	2	H0001//139661	42	10
00000//126385	52	9	H0001//139667	21	14
H0001//128573	24	8	H0001//139668	20	8
H0001//129701	14	17	H0001//139669	21	16
H0001//131482	18	3	H0001//139689	20	7
H0001//131483	18	2		23	13
H0001//132368	26	5	H0001//139727	20	18
H0001//132432	16	3	H0001//139728	20	16
H0001//132497	49	3	H0001//139729	21	12
	51	10	H0001//139730	20	17
H0001//132679	23	8	H0001//139731	25	8
H0001//132680	23	9	H0001//139732	23	12
H0001//132681	23	3	H0001//139733	21	15
H0001//132684	22	14	H0001//139734	20	9
H0001//132686	23	10	H0001//139735	20	1
H0001//132687	23	4	H0001//139736	23	14
H0001//132688	22	11	H0001//139738	21	13
	22	16	H0001//139740	24	6
H0001//132795	19	4	H0001//139741	21	18
H0001//132797	29	11	H0001//139742	24	2
H0001//132798	28	10	H0001//139743	24	13
H0001//132799	30	9	H0001//139744	20	2
H0001//134144	13	7	H0001//139745	21	11
H0001//134340	11	12	H0001//139747	21	9
D8286//13.5DIN125	44	9	H0001//139748	25	5
D8286//13.5DIN433	17	13	H0001//139749	25	4
H0001//135937	47	2	H0001//139750	24	10
H0001//135965	21	8	H0001//139751	24	1
H0001//136504	22	8	H0001//139752	20	6
H0001//136580	46	15	H0001//139753	20	13
H0001//136585	46	20	H0001//139754	24	5
H0001//136591	46	13	H0001//139755	20	3
H0001//136592	46	14	H0001//139756	21	10
H0001//136593	46	16	H0001//139757	21	17

Detaillijst NSN 2330-17-022-0065

FABRIEKSNUMMER INDEX (vervolg)

1	2	3	4	5	6
H0001//139758	24	17	H0001//144552	40	2
H0001//139759	25	6	H0001//144691	33	8
H0001//139760	25	1	H0001//144692	33	5
H0001//139761	23	15	H0001//144693	33	3
H0001//139762	24	11	H0001//144694	32	13
H0001//139768	24	3	H0001//144695	32	9
H0001//139769	21	5	H0001//144809	32	16
H0001//139771	24	16	H0001//144811	32	11
H0001//139801	21	1	H0001//144812	33	6
H0001//139802	20	19	H0001//144813	33	4
H0001//139805	20	10	H0001//144814	33	1
H0001//139806	20	11	H0001//144842	9	5
H0001//139807	20	12	H0001//144879	46	11
H0001//139865	46	18	H0001//144988	44	6
H0001//139876	47	1	H0001//145084	19	17
H0001//139942	46	17	H0001//145124	48	7
H0001//142320	32	4	H0001//145187	9	12
H0001//142644	46	4	H0001//145189	9	1
H0001//142886	26	8	H0001//145190	9	15
H0001//143289	46	21	H0001//145217	30	3
H0001//143291	46	19	H0001//145220	35	2
H0001//143498	30	5	H0001//145221	37	10
H0001//143499	28	1	H0001//145228	22	9
H0001//143500	29	14	H0001//145510	47	13
H0001//143501	29	13	H0001//145558	12	11
H0001//143504	29	15	H0001//145559	12	8
H0001//143647	55	12	H0001//145562	12	9
H0001//143649	55	14	H0001//145620	35	10
H0001//143651	55	15	H0001//145621	40	8
H0001//143944	29	1	H0001//145622	35	17
H0001//144020	28	2	H0001//145623	41	14
H0001//144022	28	3	H0001//145624	40	11
H0001//144189	17	2	H0001//145625	35	8
H0001//144377	44	5	H0001//145626	37	4
H0001//144527	40	10	H0001//145627	37	5
H0001//144535	35	6	H0001//145628	39	11
H0001//144536	37	12	H0001//145629	37	3
H0001//144542	36	9	H0001//145630	38	7
H0001//144543	38	9	H0001//145631	38	6

Detaillijst NSN 2330-17-022-0065

FABRIEKSNUMMER INDEX (vervolg)

1	2	3	4	5	6
H0001//145633	35	11	H0001//148318	35	16
H0001//145634	41	13	H0001//148319	33	15
H0001//145636	39	14	H0001//148320	36	13
H0001//145637	40	9	H0001//148321	34	13
H0001//146085	17	9	H0001//148322	37	15
H0001//146086	17	10	H0001//148323	37	11
H0001//146143	18	10	H0001//148325	40	15
H0001//146184	30	7	H0001//148326	40	13
H0001//146190	18	11	H0001//148327	36	3
H0001//146206	49	14	H0001// 148328	36	1
H0001//146675	19	12	H00 1//148329	39	16
H0001//146755	38	16	H0001//148330	37	8
H0001//146879	43	8	H0001//148333	39	7
H0001//147295	44	6	H0001//148334	36	8
H0001//147403	42	16	H0001//148335	35	3
H0001//148246	52	1	H0001//148336	41	8
H0001//148247	53	18	H0001//148337	41	10
H0001//148251	29	6	H0001//148338	37	16
H0001//148252	29	4	H0001//148339	41	5
H0001//148253	29	5	H0001//148340	35	7
H0001//148254	30	8	H0001//148341	33	9
H0001//148257	28	5	H0001//148342	40	7
H0001//148258	31	4	H0001//148343	34	15
H0001//148301	38	15	H0001//148344	34	6
H0001//148302	35	13	H0001//148345	38	3
H0001//148303	35	1	H0001//148346	41	7
H0001//148304	33	10	H0001//148350	39	5
H0001//148305	34	4	H0001//148351	39	15
H0001//148306	38	2	H0001//148352	40	4
H0001//148307	40	6	H0001//148353	39	6
H0001//148308	40	1	H0001//148354	34	7
H0001//148309	40	5	H0001//148355	41	3
H0001//148310	39	10	H0001//148356	37	1
H0001//148311	41	12	H0001//148357	36	10
H0001//148312	38	4	H0001//148358	41	2
H0001//148313	39	4	H0001// 148359	34	8
H0001//148314	36	11		35	14
H0001//148317	39	9	H0001//148360	33	11

FABRIEKSNUMMER INDEX (vervolg)

1	2	3	4	5	6
H0001//148363	36	12	H0001//154178	27	13
H0001//148443	42	9	H0001//154180	27	19
H0001//148444	42	13	H0001//154181	27	6
H0001//148990	13	1	H0001//154182	26	11
H0001//148992	13	3	H0001//154184	27	2
H0001//149108	53	10	H0001//154185	27	3
H0001//149123	17	5	H0001//154186	27	1
H0001//149124	19	15	H0001//154187	26	15
H0001//149405	26	12	H0001//154188	27	15
H0001//149442	30	4	H0001//154189	27	9
H0001//149471	21	20	H0001//154191	27	7
H0001//149472	22	1	H0001//154252	31	7
H0001//149720	19	13	H0001//154253	28	8
H0001//149973	48	17	H0001//154356	47	19
H0001//150370	48	4	H0001//154365	26	13
H0001//150682	49	19	H0001//154396	22	3
H0001//150683	49	18	H0001//154645	11	15
H0001//150715	49	1	H0001//155058	24	9
H0001//150716	49	2	H0001//155090	27	8
H0001//150783	44	16	H0001//155092	28	9
H0001//150917	23	11	H0001//155093	31	8
H0001//151018	47	3	H0001//156854	12	10
H0001//151043	48	13	H0001//158326	11	1
D8286//1.5x20DIN94	36	16	H0001//158327	11	4
	50	11	H0001//158328	12	3
	54	3	H0001//158330	11	7
H0001//152472	50	16	H0001//158331	11	18
H0001//152474	50	17	H0001//158332	10	6
H0001//152482	49	6	H0001//158333	10	12
H0001//152483	50	13	H0001//158429	18	6
H0001//152485	50	7	H0001//158562	53	14
H0001//152490	49	13	H0001//158936	51	17
H0001//152914	50	2	H0001//158941	52	8
	52	11	H0001//158953	54	12
H0001//152988	30	2	H0001//158955	53	7
H0001//152997	51	5	D2598//1621/E27	9	9
H0001//153051	49	9	00000//180079	28	6
H0001//153654	11	9		33	12
H0001//153656	13	5		33	16
				34	2

Detaillijst NSN 2330-17-022-0065

FABRIEKSNUMMER INDEX (vervolg)

1	2	3	4	5	6
00000//180122	29	2	H0001//186395	32	12
00000//180175	42	11	H0001//186396	33	7
H0001//180214	55	1	H0001//198720	22	13
00000//181003	9	2	H0001//198922	20	5
	10	1	06853//200360	31	7
	14	3	06853//200361	28	8
	18	7	D8286//20x1DIN472	32	7
	48	1	H0001//202N108	50	1
H0001//180080	52	15		52	10
00000//181558	25	12	06853//202735	37	11
00000//181561	29	9	00000//202817	19	5
00000//181567	16	10		49	11
	16	14	H0001//203N106	9	3
00000//181573	49	4		10	2
	51	11		14	11
00000//181580	51	6		16	11
00000//181595	53	2		16	15
00000//181608	44	12		48	2
	46	9	H0001//203N108	27	4
	53	11		39	2
00000//181618	18	12	H0001//203N110	47	11
00000//181635	47	14		47	16
	48	9		48	11
00000//181636	25	2		48	15
	48	14		49	16
00000//181639	38	11		52	6
	47	10	H0001//203N112	54	16
00000//181643	22	4		45	7
	27	12		46	1
	47	15	H0001//203N116	53	16
00000//181648	52	2	H0001//203N206	26	14
00000//181650	54	15	H0001//203N212	18	8
00000//181652	49	15		18	1
	52	5		20	4
00000//181696	44	7	06853//203388	23	6
00000//181698	44	8	06853//203754	40	15
00000//181700	53	15	06853//203755	28	9
H0001//191816	53	1	H0001//204208	31	8
H0001//181852	44	11	06853//204239	12	2
H0001//181897	18	5	06853//204261	33	13
H0001//182170	33	13	H0001//204353	34	15
K0092//18234/4	26	10	H0001//204361	18	5
H0001//183199	54	14	H0001//204493	10	4
H0001//183932	33	2	06853//205053	10	7
				28	1

FABRIEKSNUMMER INDEX (vervolg)

1	2	3	4	5	6
06853//233809	39	7	06853//239216	34	5
06853//233810	36	12	H0001//256N410	14	6
06853//233812	33	9		55	11
06853//233813	39	16	H0001//256N420	9	8
06853//233814	34	6	H0001//256N530	51	13
06853//233815	39	5	H0001//256N612 cd	11	14
06853//233819	41	5		32	15
06853//233937	35	1	D8286//26DIN1441	19	13
06853//233938	33	10	H2428//CR26.5/19.5	24	7
06853//234146	27	3	00000//271506	21	3
06853//234243	41	10	00000//271744	22	5
06853//234362	27	6	H0001//273N610	25	12
06853//234365	27	18	H0001//273N616	9	2
06853//234557	41	12		10	1
06853//234558	35	16		14	3
06853//234559	39	10		18	7
06853//234560	40	6		48	1
06853//234761	34	13	H0001//273N622	16	10
06853//234839	40	3		16	14
06853//235255	27	1	H0001//273N825	44	12
06853//235356	27	8		46	9
06853//235257	27	15		53	11
06853//235260	27	9	H0001//273N832	9	13
06853//236304	37	14	H0001//290N125	45	9
06853//237598	39	8	H0001//302000	55	8
06853//237599	36	14	H0001//304328	38	14
06853//237605	35	15	H0001//304331	34	16
06853//237606	41	11	H0001//304334	41	11
06853//238026	34	16	H0001//304335	39	8
06853//238030	41	9	H0001//304336	36	14
06853//238032	41	4	H0001//304337	35	15
06853//238035	35	9	H0001//304342	40	12
06853//238039	41	6	H0001//304343	36	2
06853//238107	38	1	H0001//304344	35	9
06853//238127	34	14	H0001//304346	41	9
06853//238172	34	1	H0001//304347	41	4
06853//238376	38	5	H0001//304348	40	3
06853//238656	35	4	H0001//304349	34	14
06853//238657	37	2	H0001//304352	41	6
			H0001//304957	22	12
			H0001//309514	31	2
			24617//310952	26	1

Detaillijst NSN 2330-17-022-0065

FABRIEKSNUMMER INDEX (vervolg)

1	2	3	4	5	6
H0001//316014	46	3	H0001//325292	47	8
H0001//316015	45	8	H0001//325294	21	7
H0001//316205	31	10	H0001//325295	24	4
H0001//316206	43	6	H0001//325377	19	14
H0001//316209	21	19	H0001//325410	45	16
H0001//320659	47	6	H0001//325421	18	15
H0001//323N215	18	14	H0001//325435	37	7
	49	10		37	9
H0001//323N230	54	6	D8286//3.2DIN6799	32	8
H0001//323N315	38	8	H0001//327037	45	4
H0001//323N320	19	2	D8286//33DIN7457	43	15
	38	8			
	54	8	H0001//339205	38	10
H0001//323N330	54	17	H0001//339207	35	5
H0001//323N420	19	7	H0001//339208	35	4
	19	10	H0001//339209	37	2
	53	19	H0001//339210	37	14
	53	21			
	54	10	H0001//339211	38	1
H0001//323N435	17	12	H0001//339212	34	5
	44	17	H0001//339213	38	5
H0001//323N640	53	8	H0001//339214	34	1
H0001//324026	45	10	H0001//346219	53	4
H0001//324030	46	8	H0001//346573	37	6
H0001//324054	45	15	H0001//346630	23	1
H0001//324076	32	3	H0001//346817	30	11
H0001//324183	14	2	H0001//346818	31	1
	28	4	H0001//347467	10	14
H0001//324237	13	4	H0001//353707	54	13
H0001//324636	43	4	H0001//354480	13	6
H0001//324730	23	16		31	6
H0001//324750	43	11	H0001//355378	44	15
H0001//324797	20	15	H0001//361N012	28	7
H0001//324967	12	4	H0001//361N008	25	10
H0001//325015	25	15	H0001//361N012	25	11
H0001//325017	26	7	H0001//361N016	29	8
H0001//325031	19	13	H0001//361N116	13	16
H0001//325026	19	11	H0099//Svtg 3998(1.5)	13	10
H0001//325N215	19	16	H0050//400-056	15	1
H0001//325275	30	10	H0050//400-90	15	11
	32	2			
H0001//325291	47	7	H0050//400-073	15	3

FABRIEKSNUMMER INDEX (vervolg)

1	2	3	4	5	6
H0050//400-074	15	4	H0001//453N112	26	4
D8286//AM4x10DIN84-4S	14	6		46	2
	55	11		53	17
00000//420690	50	9	H0001//453N116	22	7
	51	4		26	15
D8286//M4x20DIN84-4S	9	8	H0001//453N208	44	14
	13	15	H0001//453N212	42	12
				44	10
00000//421575	55	7			
H0001//423N079	53	5	H0001//455N008	53	3
00000//426324	55	5	H0001//455N012	23	7
				44	9
00000//427079	55	16	H0001//455N025	45	10
00000//432768	12	12	00000//501229	43	15
00000//432769	12	13	00000//501658	42	3
00000//444688	27	16	00000//503 404	45	9
00000//444691	27	17	00000//504208	45	3
H0001//451N104	9	7	00000//507404	18	10
	13	14			
	55	10	00000//0520944	43	16
H0001//451N105	44	3	D8286//AM5x30DIN84-4S	51	13
D8286//451N106	11	13	D8286//A5.3DIN6798	17	7
H0001//451N205	17	7	00000//538824	42	4
H0001//451N208	44	14	00000//538825	42	5
	53	13	00000//538826	42	6
H0001//453N105	44	3	H0001//551474	10	13
H0001//453N106	9	4	H0001//554130	27	11
00000//103319	10	3			
	14	14	H0001//561473	10	13
	14	12	H0001//563614	11	19
	16	12			
	16	16	00000//570501	53	6
	29	10	H0001//584886	32	6
	48	3			
	50	5	H3067//6023-22	11	8
	51	9			
	52	14			
H0001//453N108	9	14	D8286//A16x12DIN84-4S	11	14
				32	15
H0001//453N110	22	2	H0001//693N110	45	3
	22	6			
	27	14	00000//705322	43	1
	29	3	00000//706687	42	15
	38	13			
	47	12	00000//706771	42	14
	47	18			
	48	12	H0001//817N108	26	10
	48	16	H0001//817N206	25	9
	49	17			
	52	3	D8286//8 x22DIN660	46	5
	52	7		46	7

Detaillijst NSN 2330-17-022-0065

FABRIEKSNUMMER INDEX (vervolg)

1	2	3	4	5	6
H0001//833501	21	6	D8286//30x1.5DIN471	17	4
H0001//8.367D60	42	8	H0001//3184060	19	9
D8286//A8.4DIN6798	53	13	H0001//319N16005	53	20
H0001//849N215	29	11	H0001//322N0322	27	10
H0001//849N315	31	9	H0001//323N1520	50	11
H0001//850N415	30	6	96906//35338-22	55	6
H0001//851N315	30	1	96906//35338-25	18	9
H0001//909N103	16	7	D8286//4x20DIN1471	39	13
H0001//909N153	31	5	H0001//04N207503	47	4
H0001//909N151	16	8	H0099//TEK 423 b1z 12-13	26	6
04636//914007	47	6		27	13
H0001//927N025	18	17		38	12
H0001//927N030	18	18		47	11
H0001//10.551D60	43	6	H0001//455V42/03	52	2
H0001//1203N206	49	5	H0001//457N3020	32	7
	51	8	H0001//458N2030	17	4
	51	12	H0001//458N3065	32	8
	52	16			
78500//1227-T-228	43	3	D8286//DIN49360/E27/6	9	10
H0001//12N900 12M	43	14	H0001//515N0456	15	5
H0001//200319E1	51	4	H0001//515N0457	15	6
U1980//20369-S7/8	25	2	H0001//515N0458	15	7
H0001//228N06038	48	8	H0001//515N0459	15	8
D8286//25x1.2DIN471	17	3	H0001//515N046/1	15	9
H0001//263N1038	22	4	H0001//515N046/2	15	10
	27	12	H0001//515N0490	15	11
H0001//263N1050	52	2	96906//51922-61	46	12
H0001//263N1064	54	15	D8286//5x36DIN1473	39	12
H0001//263N1132	21	2	H0001//620G18V13	20	14
H0001//273N1019	48	9	D8286//M8x30DIN931-86	35	12
H0001//273N1022	48	14	H0001//8.368060	43	3
H0001//273N1032	38	11	00000//8376209	16	9
	47	10	96906//90725-12	50	3
H0001//273N1076	49	15		52	12
	52	5	96906//90725-40	40	14
H0001//273N1225	44	7	96906//90726-39	18	12
H0001//273N1232	44	8	H0001//908N0091	45	4
H0001//273N1238	53	15	H0001//10N316013	43	5
H0001//273N1638	22	5	78500//1229-G-1021	42	8
H0001//276N05010	17	6	H0001//14N218279	43	13

FABRIEKSNUMMER INDEX (vervolg)

1	2	3	4	5	6
H0007//151-180-04	47	4	H0001//455N308/03	33	17
D8286//16h11x80x75DIN1435	54	9		40	16
H0001//20104141	50	6	D8286//A48x55DIN7603fi	37	13
	53	9	D8286//DIN49360/E27/15	9	11
D8286//M20x1.5DIN934-6S	43	10	H0001//504N10408	14	7
H0001//202N106/03	48	6	H0001//515N04056	15	1
	48	10	H0001//515N04057	15	2
	50	4	H0001//515N04073	15	3
	50	16	H0001//515N04074	15	4
H0001//203N106/03	10	2	H0001//515N04580	15	12
H0001//203N108/03	50	8	H0001//515N04581	15	13
	51	3	H0001//515N04585	15	14
	53	12	H0001//515N04586	15	15
H0001//203N212/03	26	3	H0001//515N04591	15	16
D8286//C20.5DIN74361	43	5	H0001//515N04595	15	17
H0001//206N105/03	44	2	H0001//515N04596	15	18
H0001//208N108/03	18	13	H0001//525N40105	13	8
H0001//208N212/03	17	11	H0001//525N40106	13	9
D8286//C22x27DIN7603	32	2	H0001//525N40406	13	10
H0001//228N06038	50	14	D8286//M813.5DIN564-5S	32	9
	51	1	D8096//001.280.00.052	32	11
	51	15	D8096//001.280.04.051	32	12
H0001//238N06038	48	5	D8096//001.284.01.066	32	16
H0099//25x1.2Svtg 4264	17	3	D8096//001.284.01.076	33	3
96906//25690-402	50	15	D8096//001.284.01.081	33	8
H0001//259N12210	45	6	D8096//001.284.02.071	32	13
H0001//273N612/03	13	17	D8286//13.5x21x2DIN433	17	13
	14	10	D8096//001.996.00.036	40	2
	29	9	96906//20365-1216A	46	12
H0001//318N08040	54	5	D8096//002.290.00.070	33	6
H0001//318N10030	54	7	D8096//002.292.00.021	36	9
H0001//323N530/14	49	7	D8096//002.292.00.031	33	1
23000//33797-316	12	13	H0001//263N1038/03	47	15
96906//35690-402	52	13	H0001//272N1025/03	29	2
H0001//361N016/03	29	8	H0001//272N1232/03	42	11
H0001//370N121/03	29	12	H0001//273N1019/03	47	14
00000//44T.5080-15	25	16	D8096//002.999.01.014	38	9
00000//44T.5080-20	26	1	H0001//323N1520/14	36	16
00000//44T.5080-25	30	11		54	3
H0001//453N212/03	42	12	H0001//455N3091/03	33	14
	44	10			
H0001//455N004/03	13	13			
H0001//455N010/03	47	17			

Detaillijst NSN 2330-17-022-065

FABRIEKSNUMMER INDEX (vervolg)

1	2	3	4	5	6
H0001//455N3101/03	19	4	D8096//051.240.01.061	41	13
H0001//515N04110/1	15	19	D8096//097.996.00.001	40	9
H0001//515N04110/2	15	20	D8286//6h118x15.5DIN1435	54	2
H0001//515N04110/3	15	21	D8096//113.996.00.001	40	8
D8615//NSR5179/13x843	12	1	D8096//8935-070-060-4	31	9
D8096//005.290.03.070	33	7	D8286//6h11x18x15.5DIN1435	50	10
D8096//005.292.01.031	33	2	D8286//8h11x40x37DIN1435 St 50	25	5
D8096//007.997.00.008	37	7			
H0001//918N202738	37	13			
D8096//011.997.00.008	37	6			
D8286//12h11x35DIN4335	19	6			
D8096//012.996.00.001	33	4			
D8096//013.996.00.001	33	5			
D8096//022.996.00.001	40	10			
D8096//022.997.00.001	37	12			
D8096//024.996.01.001	40	11			
D8096//025.240.04.096	38	7			
D8096//025.242.02.011	35	11			
D8096//025.242.00.176	35	6			
D8096//025.242.01.221	41	1			
D8096//025.242.02.151	35	8			
D8096//025.242.03.181	38	6			
D8096//026.240.00.001	38	16			
D8096//026.240.00.060	35	17			
D8096//026.242.00.006	35	10			
D8096//026.242.00.041	41	14			
D8096//026.242.00.078	37	4			
D8096//026.242.00.116	39	11			
D8096//026.242.00.196	37	3			
D8096//026.242.01.078	37	5			
00917// 2730232900	30	1			
00917//2730-2331.00	32	3			
D8015//2916.011.014	50 54	12 4			
H0001//318N12035/03	19	6			
D8096//434.100.002.0	32	6			
D8096//050.232.01.056	39	14			

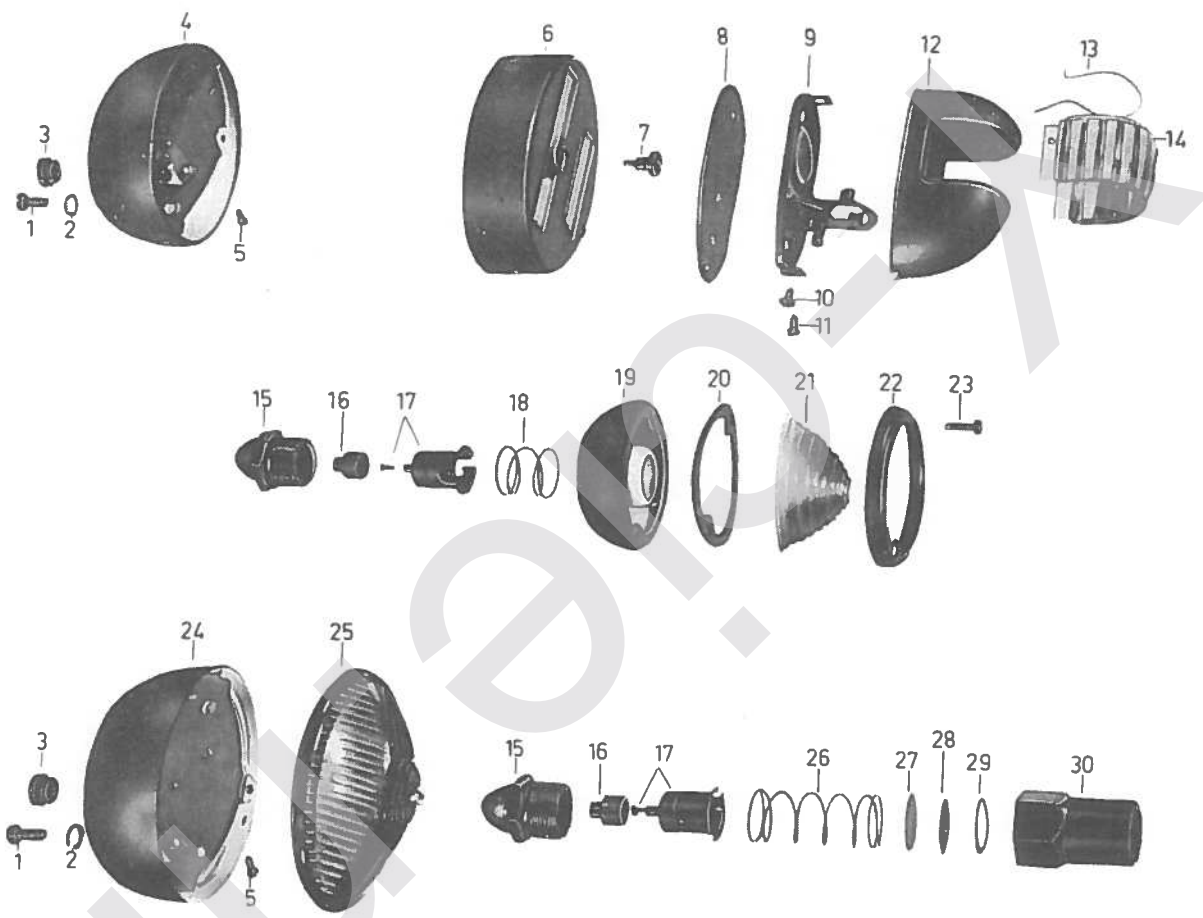

50.75

2 DL
3/5 DL

- AFB 0601 - STADS-, GRENS- en STOPAchterlampen

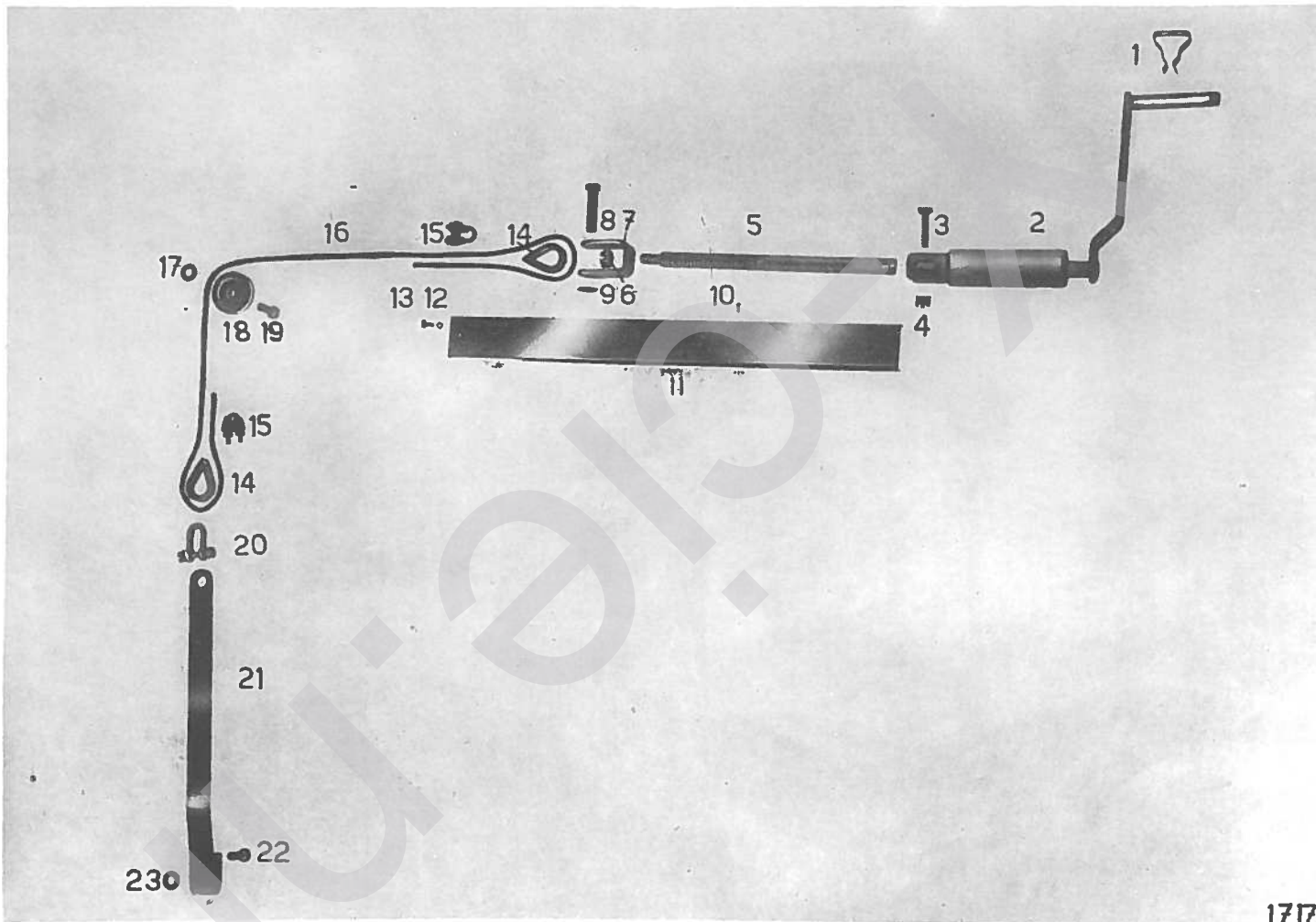

1717

2 DL
 3/5 DL - AFB 1201 - HANDREINSTALLATIE

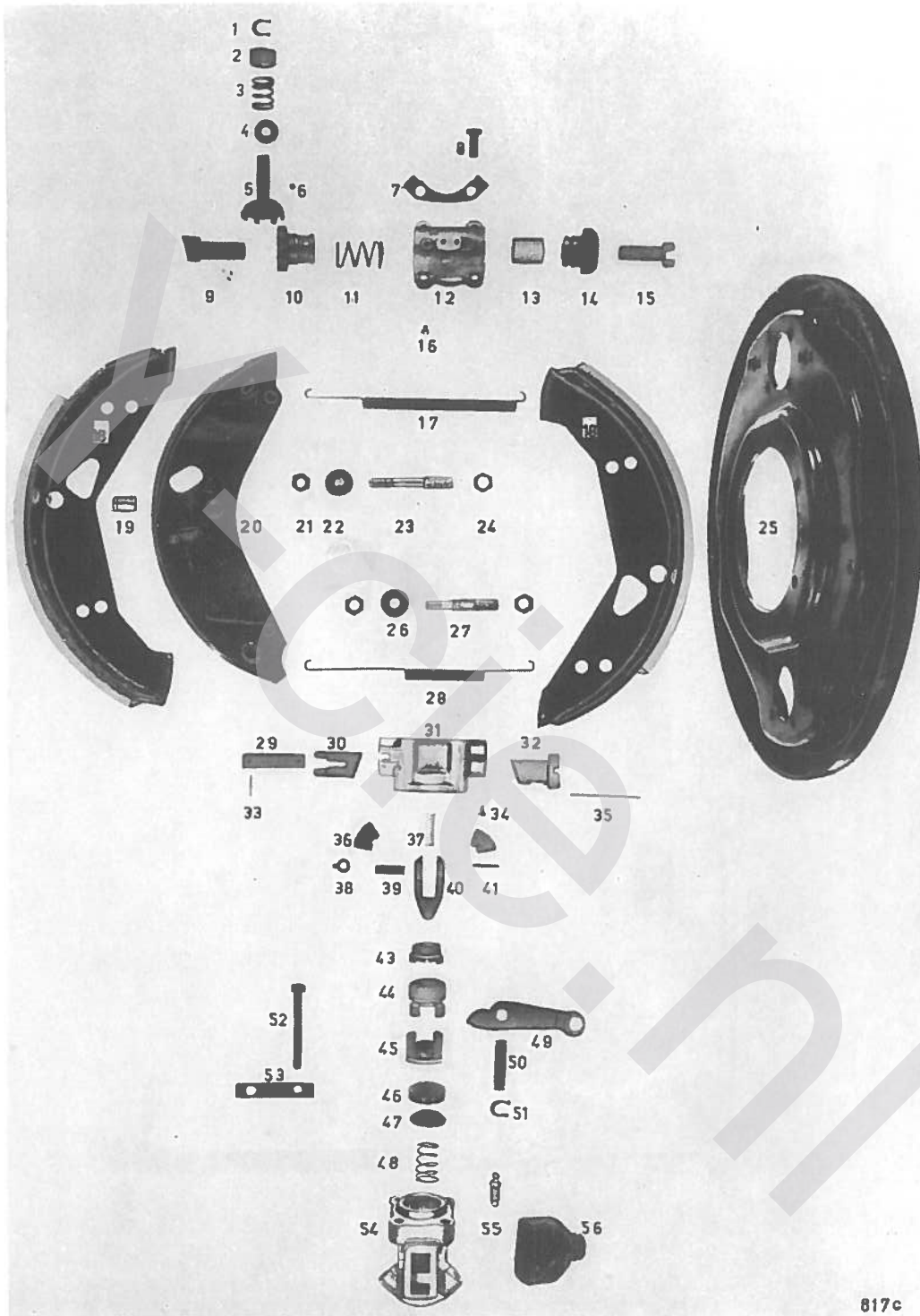

817c

2 DL - AFB 1202 - WIELREINSTALLATIE
 3/5 DL

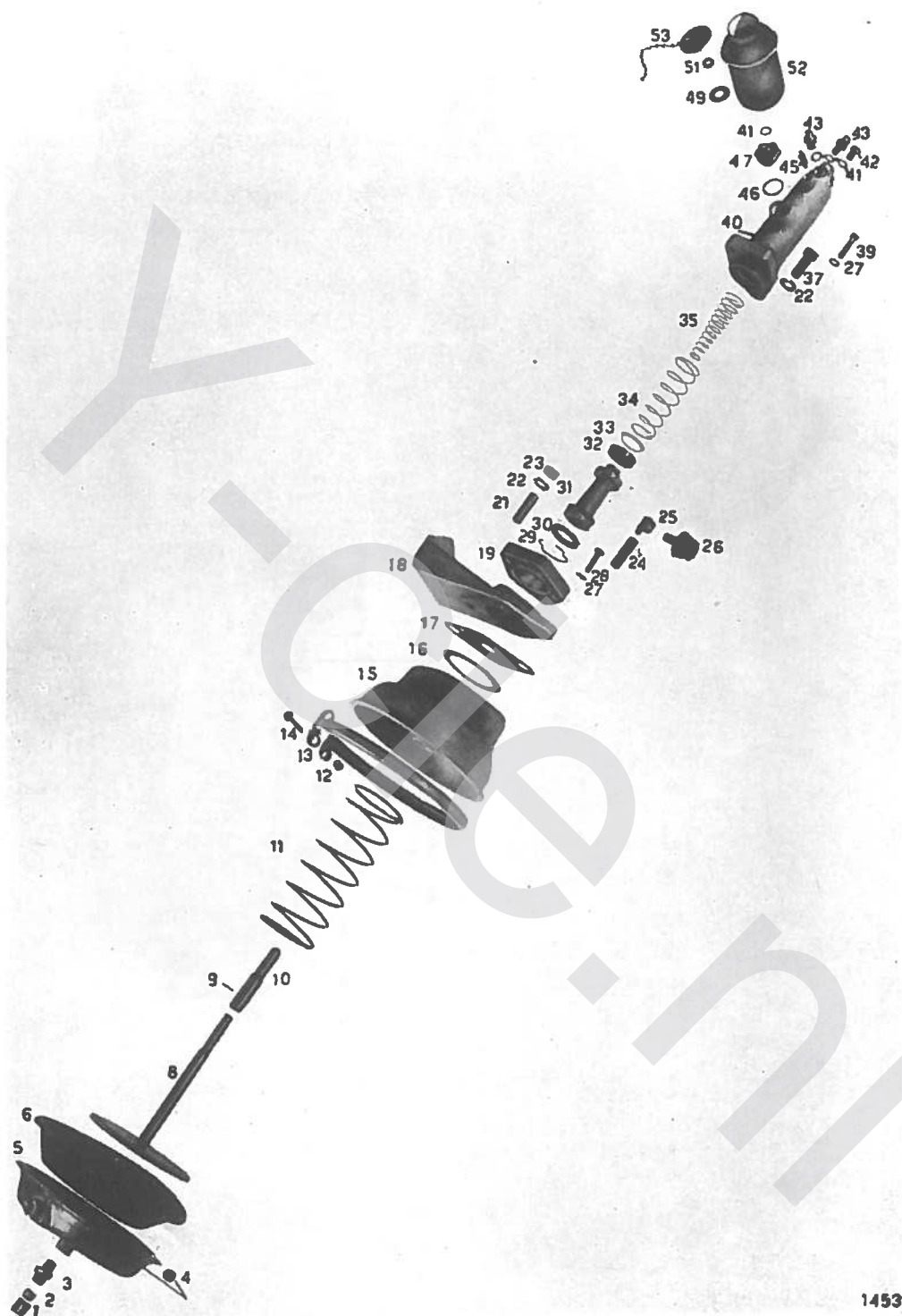

1453

2 DL - AFB 1203 - HOOFDREMCIJLINDER en REMBEKRACHTIGER
 3/5 DL

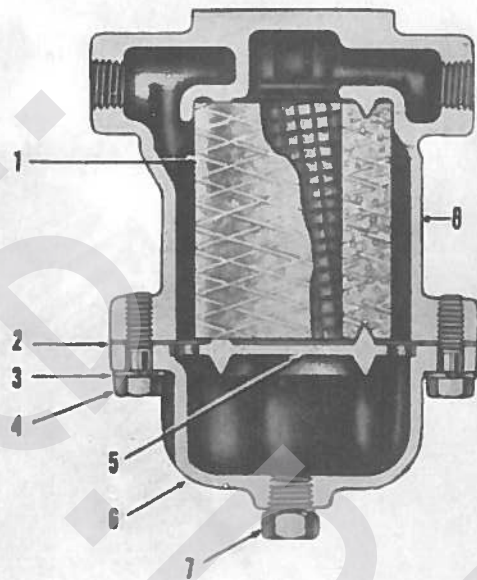

1469

2 DL
3/5 DL - AFB 1204 - LUCHTFILTER

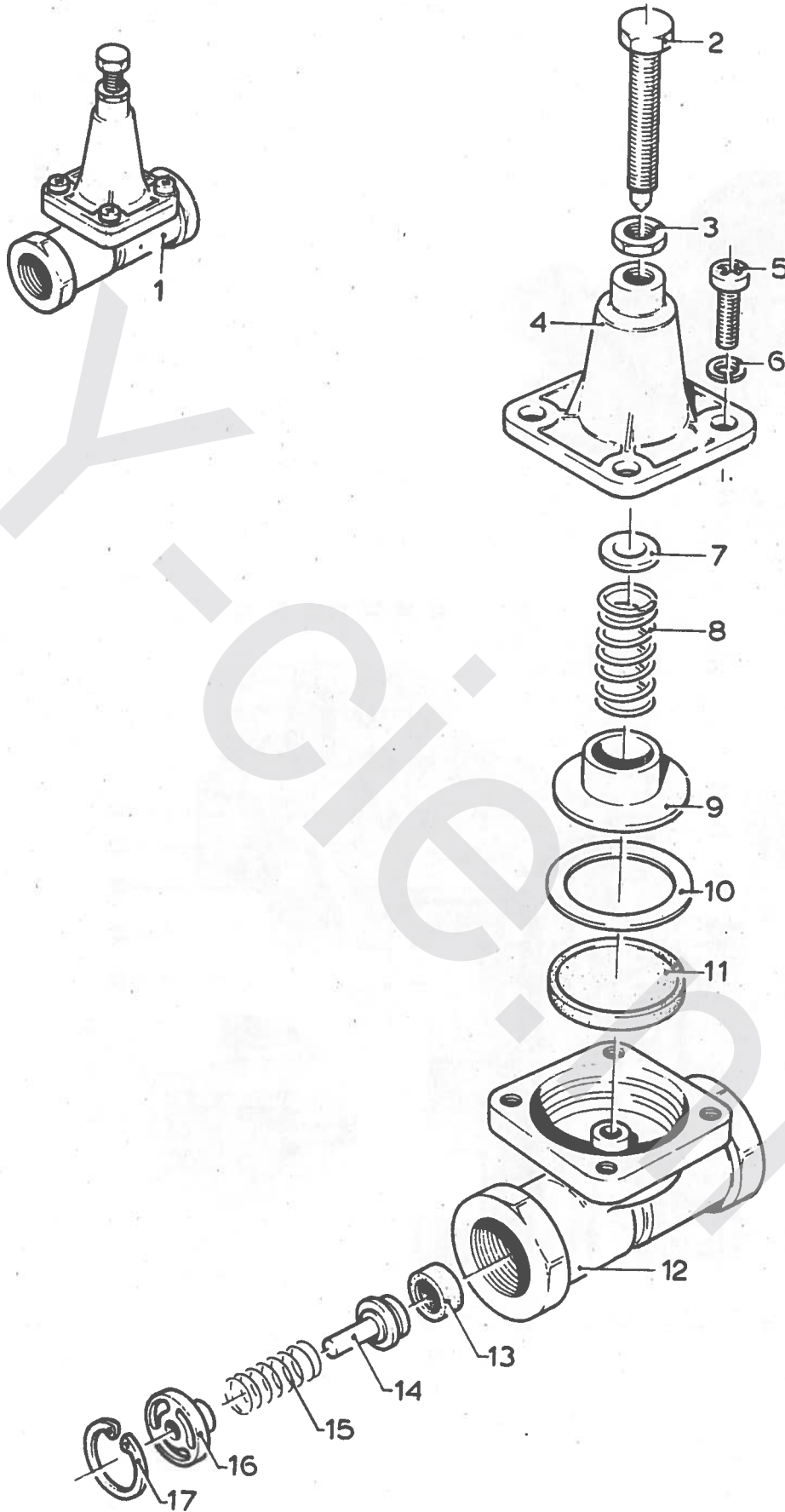

2 DL
 3/5 DL - AFB 1205 - OVERSTROOMVENTIEL

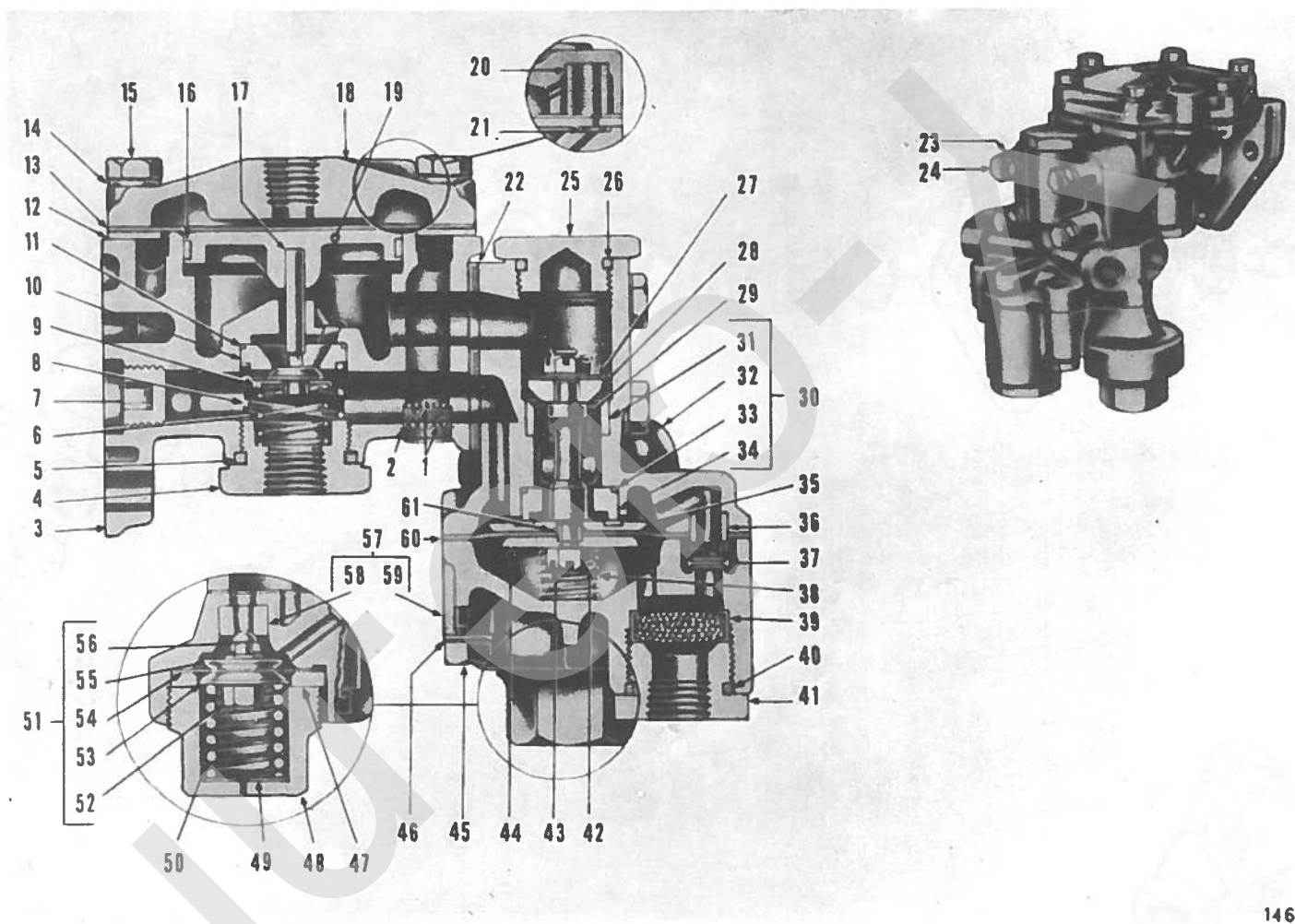

1467

2 DL - AFB 1206 - REACTIE-VEILIGHEIDSVENSTIEL
 3/5 DL

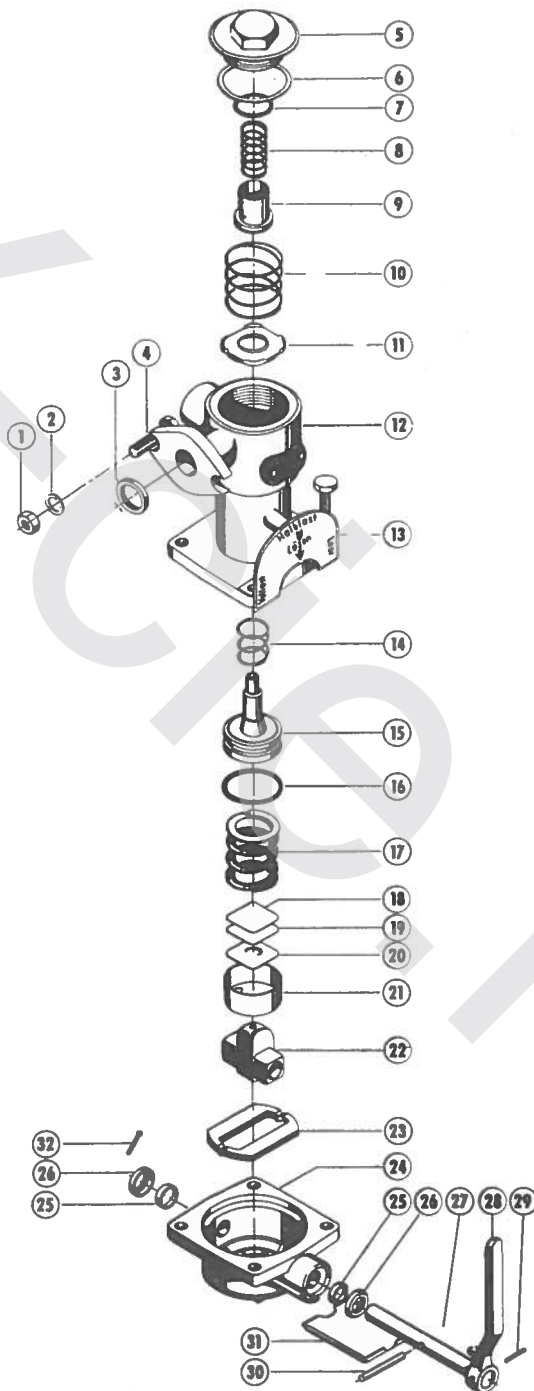

1438

2 DL
 3/5 DL - AFB 1207 - REMBEKRACHTIGER

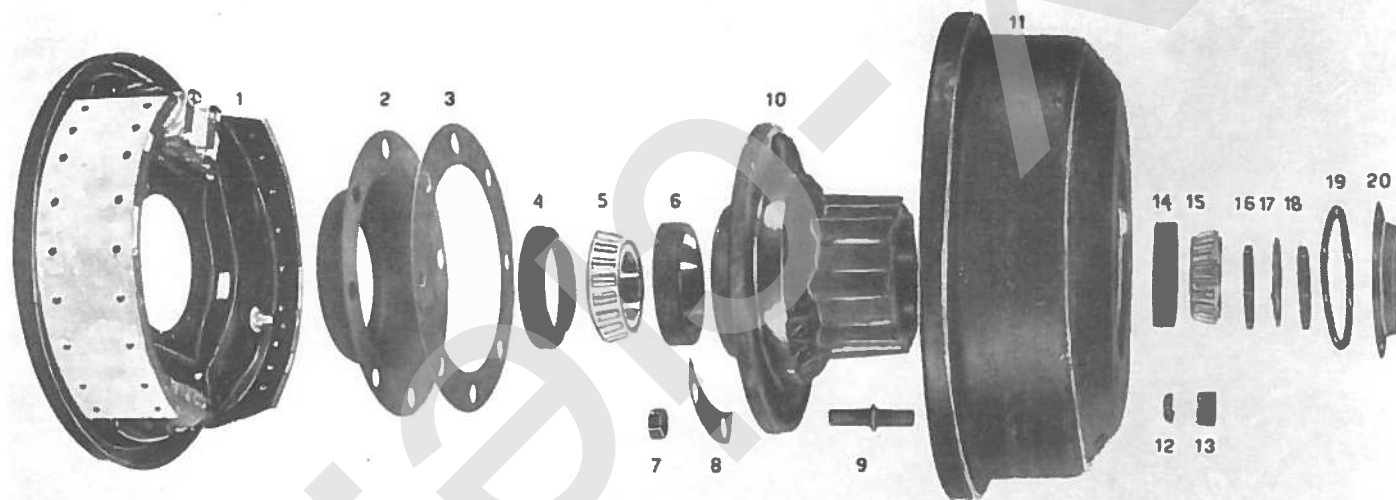

837 a

2-DL
3/5 DL - AFB 1301 - NAAF en REMTROMMEL

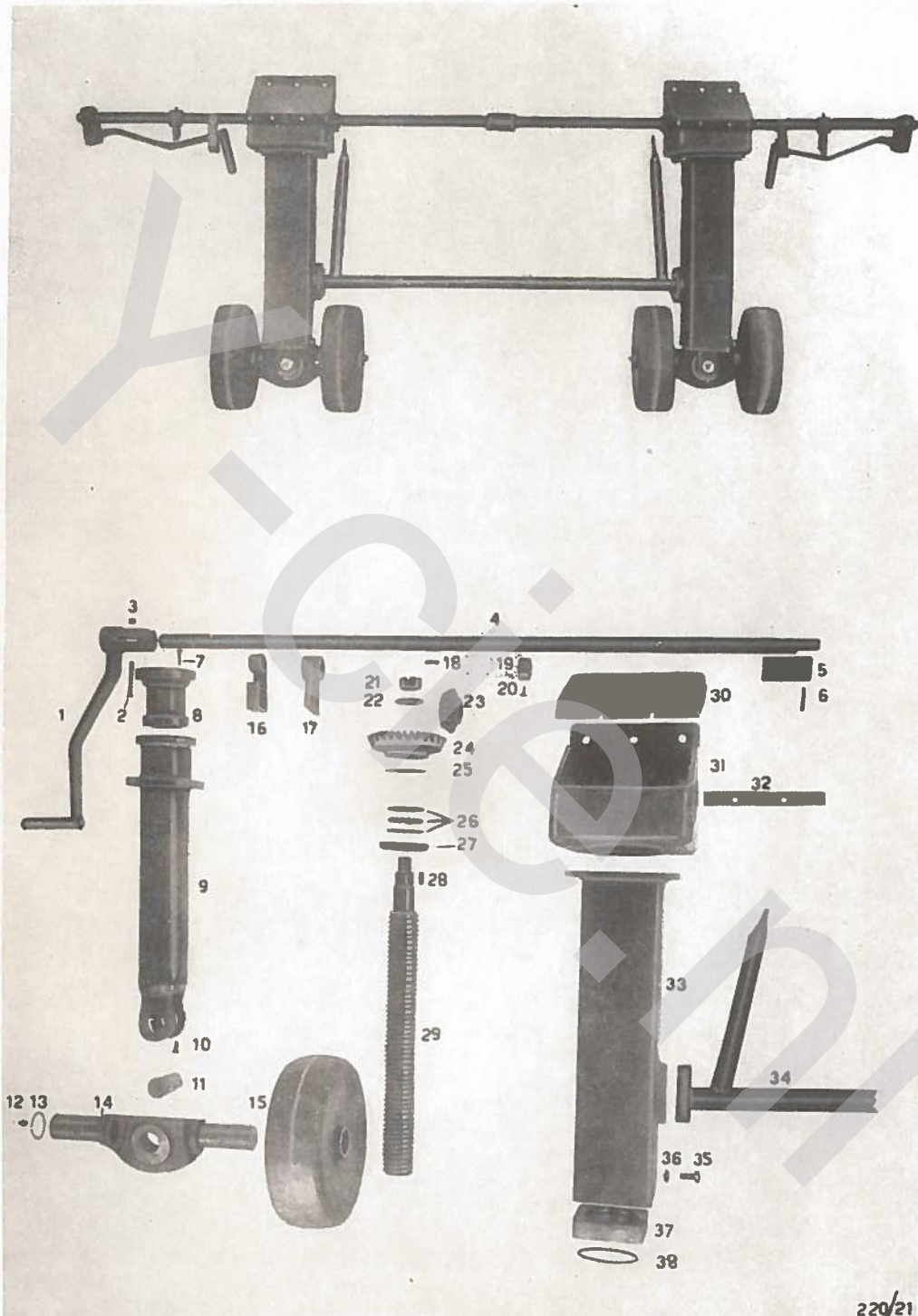

229/21

2 DL - AFB 1501 - PARKEERSTEUN
 3/5 DL